

**ROLLON**<sup>®</sup>  
BY TIMKEN

**0-Rail**

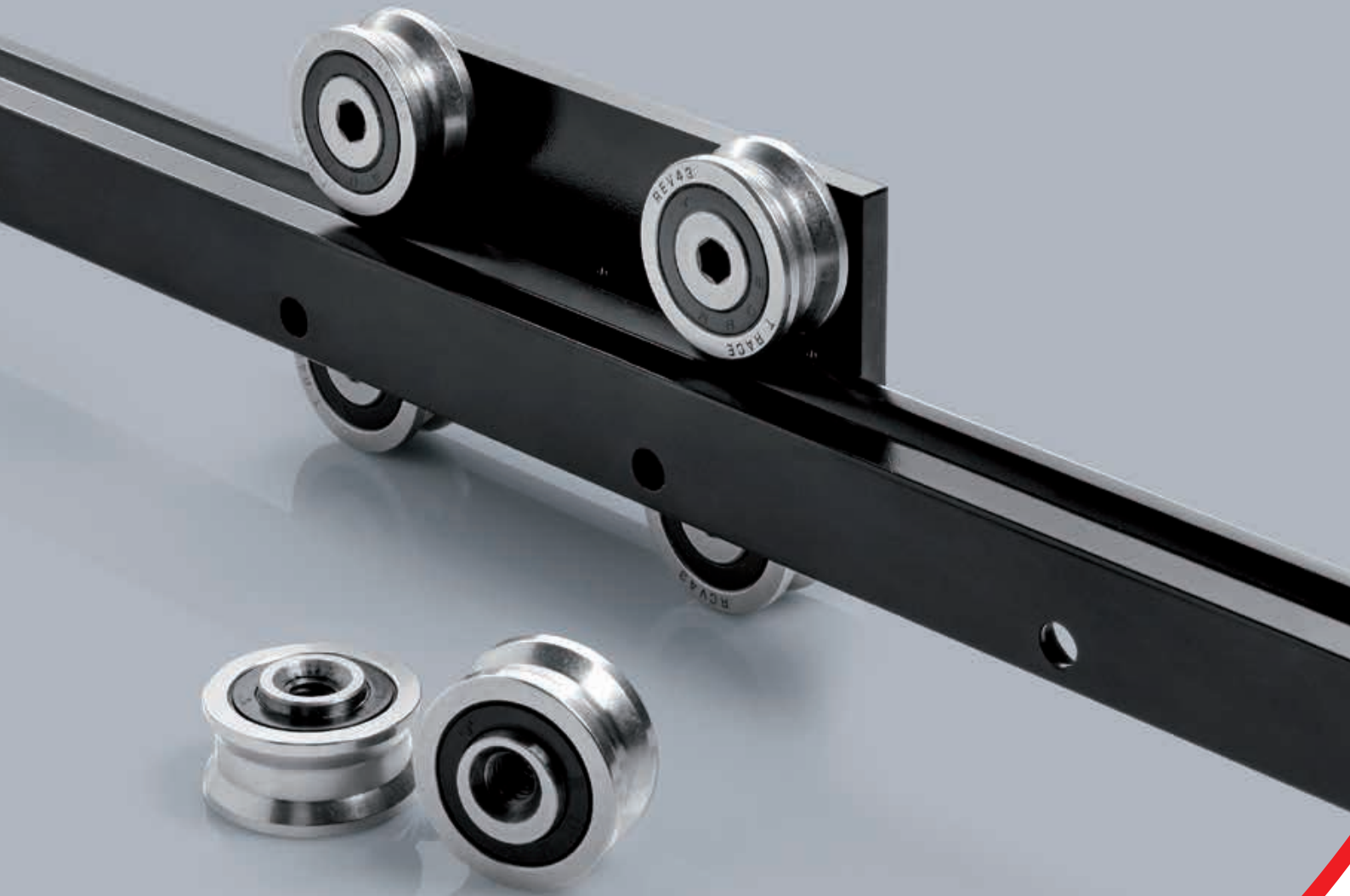



克普典科技股份有限公司  
Captain Science Corporation

---

[www.capind.com.tw](http://www.capind.com.tw)

## 聯絡方式

[citb@ms11.hinet.net](mailto:citb@ms11.hinet.net)

Line ID : @vsh6593b



### 北區

地址：10057台北市中正區信義路二段61號2樓

電話：(02) 2351-7107 轉 16 或 1

傳真：(02) 2396-4950

### 中、南區

地址：台中市神岡區中山路667巷26弄18號

電話：(04) 2561-0236 轉 11 或 18

傳真：(04) 2561-0010

## > **O-Rail**



### **1 Product explanation**

O-Rail - unique assembly possibilities, FXRG series

OR-2

### **2 General characteristics**

Configurations

OR-4

### **3 Dimensions and load capacity**

FXRG series

OR-5

### **4 Accessories**

Rollers for FXRG

OR-7

### **5 Technical instructions**

Mounting configurations

OR-8

Lubrication, Joined Rails

OR-10

Installation of joined rails

OR-12

### **Ordering key**

**Product explanation** 

**> O-Rail - unique assembly possibilities**



Fig. 1

The roller linear system O-Rail offers the maximum flexibility configuration due to the original shape of the guide with 3 raceways arranged at 90 ° to each other where on each of those can slide rollers R..43G series. Using a single guide, two, or more parallel guides, gives rise to a number of combinations capable of satisfying each specific need for linear motion and offering exceptional self-alignment capacity. O-Rail is constructed in high strength steel hardened with hardening treatments, for a further improvement of both performance and durability.

O-Rail is designed to be a strong and simple multitask linear system for larger handling and automation applications. It is an easy to assemble system, that offers smooth motion even on inaccurate surfaces.

**> FXRG series**

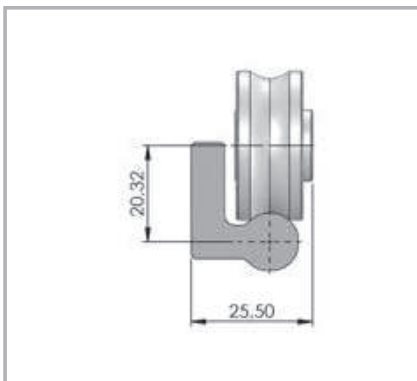

Fig. 2

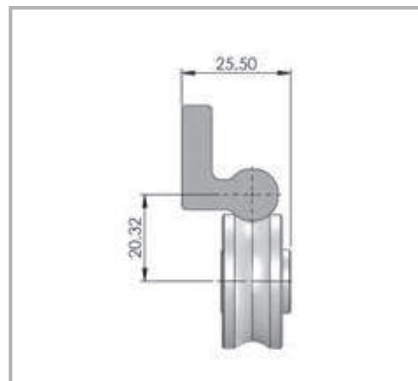

Fig. 3

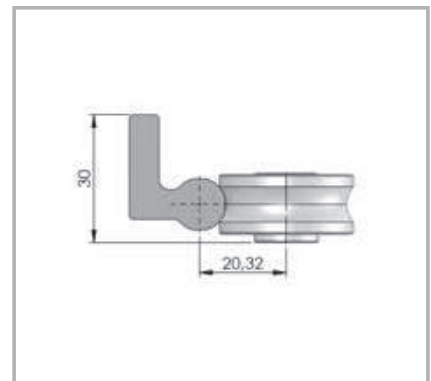

Fig. 4

## General characteristics



New geometrical design of the contact areas, based on Gothic arch raceways

- Superior sliding
- Very low friction
- Long lifetime
- Greater load capacity
- Very compact design

New rollers, double row bearings, with increased thickness of outer ring, gothic profile and finished raceways.

- Increased load capacity
- Increased lifetime
- Extremely low noise
- High speed
- Neoprene lateral seals for dust protection

Self-aligning system when using two parallel rails, compensating large assembly inaccuracies on both longitudinal and transversal plane.

- allow for installation on non precise structures - welded carpentry or aluminium frame structures
- Do not require machined fixing surfaces for installation.  
Cost saving, as easy and fast assembly

Patented process Rollon-Nox, to further improve the rail material and thermochemical hardening treatment of deep nitriding and post-oxidation black for an effective corrosion protection.

- Very high hardness
- Resistance to heavy loads
- Very low wear
- Effective corrosion protection
- Smooth black finish

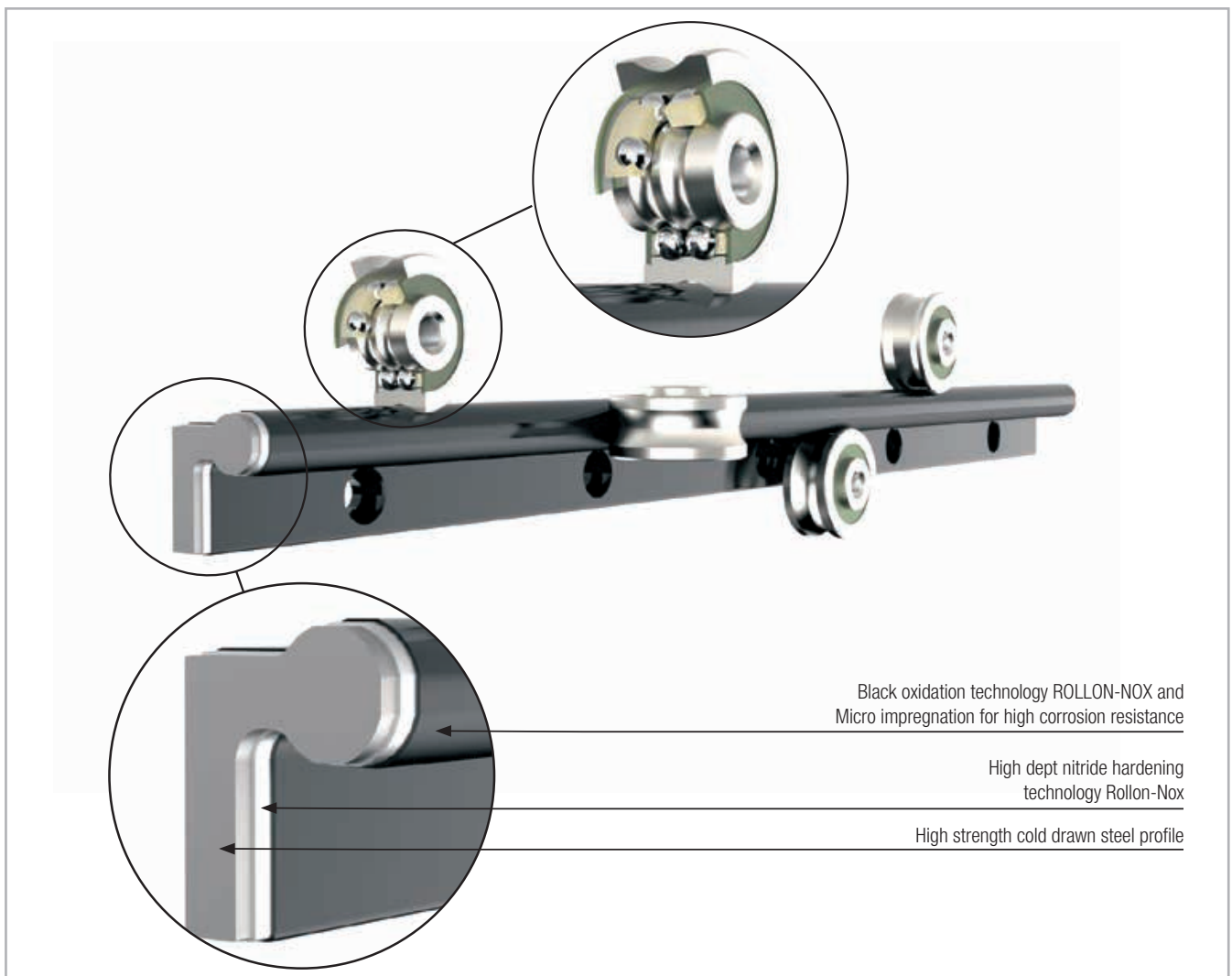

Fig. 5

## > Configurations

The FXRG allows a wide range of configurations when using two or more rails in parallel. Depending on required load and moment capacities/ direction more single rollers and standard sliders are used to obtain

unique Self-aligning systems. Contact ROLLON for eventual support in dimensioning customized systems .

FXRG with guiding slider with limited rotational capacity

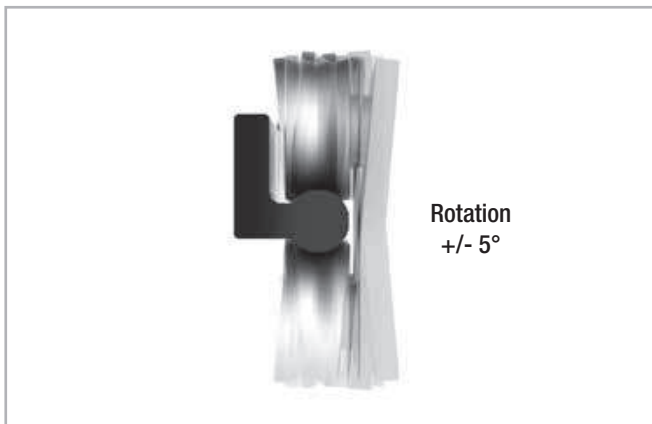

Fig. 6

Combination of two FXRG with resting load

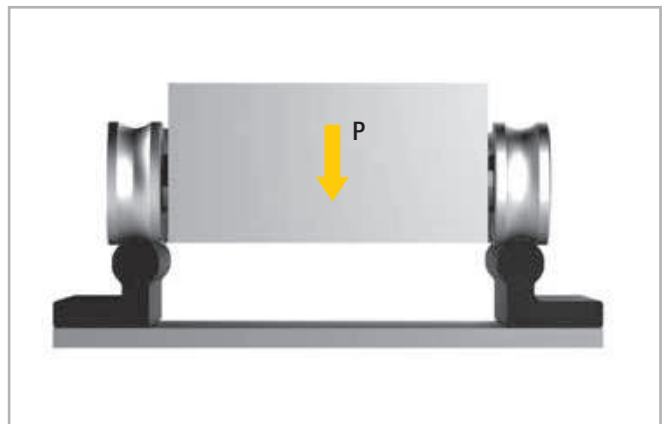

Fig. 7

Configuration with two parallel FXRG with self-aligning capacity

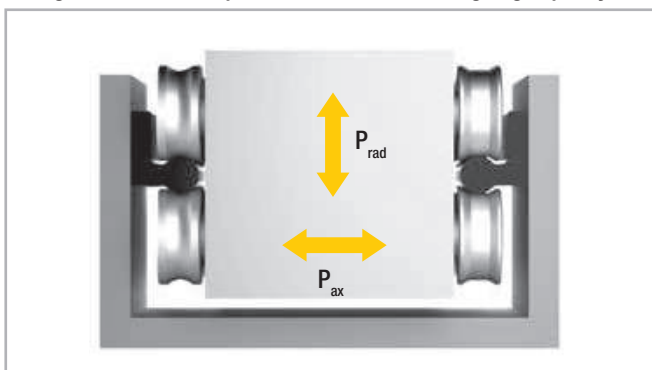

Fig. 8

Configuration with two FXRG to form a single rail with a slider allowing for high  $M_x$  moments

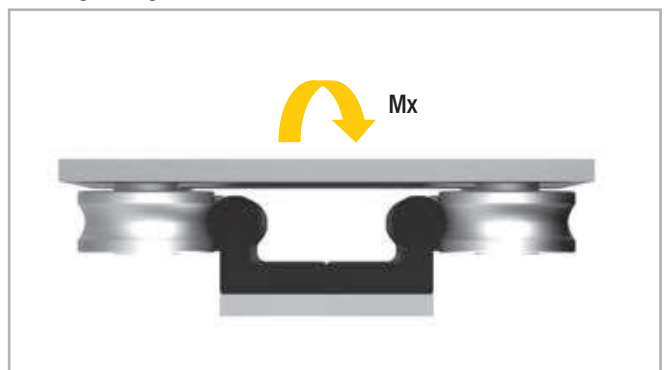

Fig. 9

Telescopic configuration

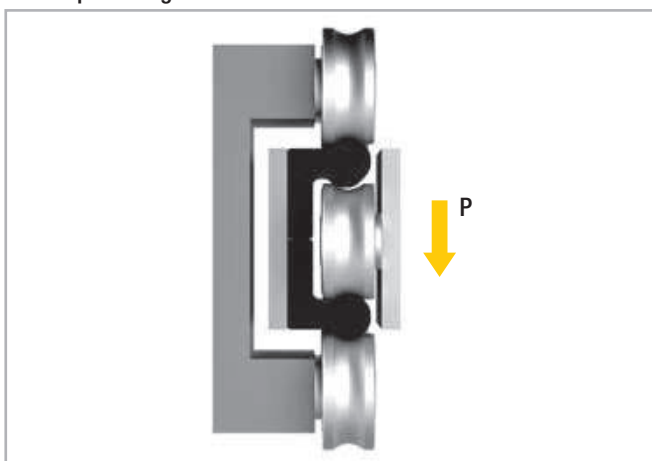

Fig. 10

Composed of two FXRG rails with rollers in between the rails fixed to mobile part and rollers on fixed structure running on outer raceways, providing a customized solutions for telescopic movements.

Configuration of two FXRG

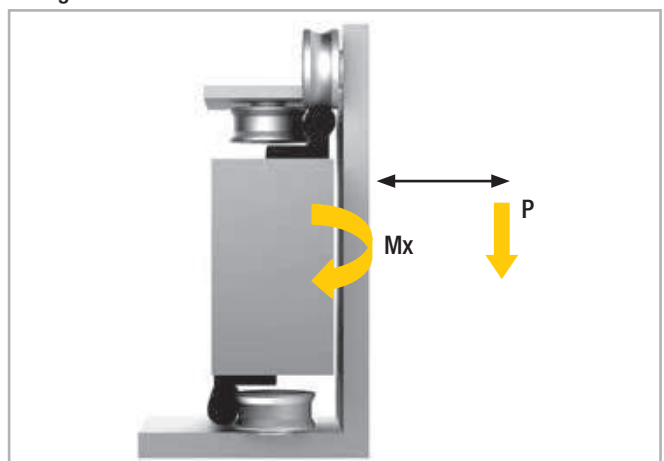

Fig. 11

With high cantilever load capacity, meanwhile Self-aligning.

# Dimensions and load capacity



## > FXRG series

FXRG is a high precision cold drawn profile of high strength steel. After a high depth nitride hardening treatment the rails are oxidized, assuring high hardness and excellent corrosion resistance. The characteristic black color on the whole rail is the result of oxidation and subsequent process

of micro-impregnation with oils and substances for improved smoothness and long life. The fixing holes are for standard M6 cylindrical low head screws, DIN 7984, with 80mm pitch .

### Position of guiding roller - Concentric RCV43G on the three raceways

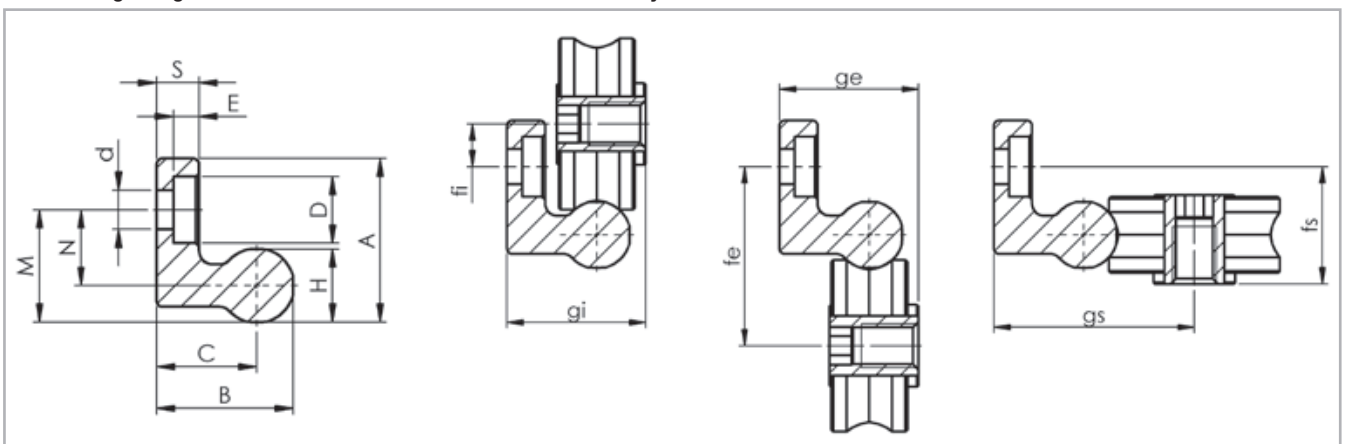

Fig. 12

Type	A [mm]	B [mm]	S [mm]	H [mm]	C [mm]	d [mm]	D [mm]	E [mm]	Screw type	M [mm]	N [mm]	Weight [Kg/m]
FXRG	27.02	22.52	7.00	12.04	16.50	6.50	11.00	4.20	M6 DIN 7984	18.52	12.50	2.48

Tab. 1

### Axial movement of floating roller R.P43G with FXRG

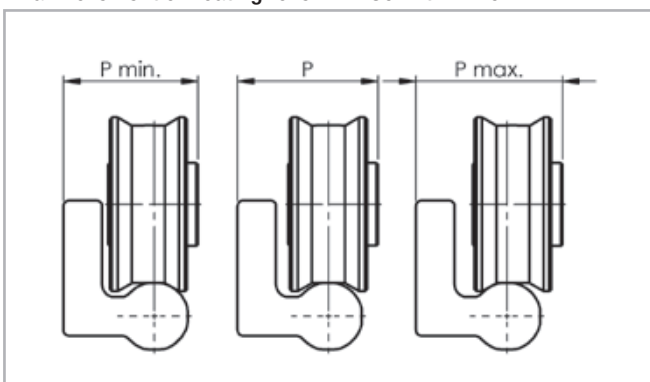

Fig. 13

### Rotation of guiding roller R.V43G on FXRG

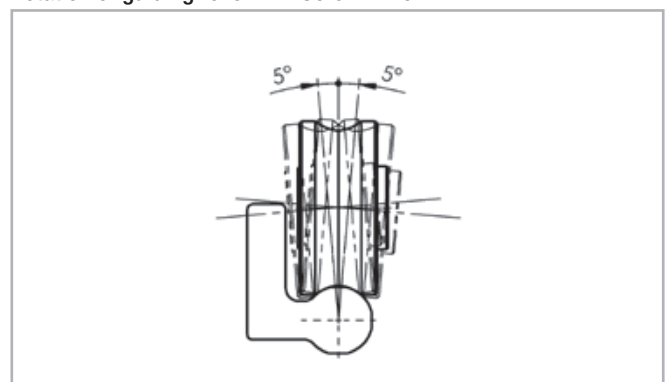

Fig. 14

Type	P [mm]	movement	P <sub>min</sub> [mm]	P <sub>max</sub> [mm]
FXRG	25.50	+/-1	24.50	26.50

Tab. 2

fi [mm]	gi [mm]	fe [mm]	ge [mm]	fs [mm]	gs [mm]
7.82	25.50	32.82	25.50	21.50	36.82

Tab. 3

Available lengths and types

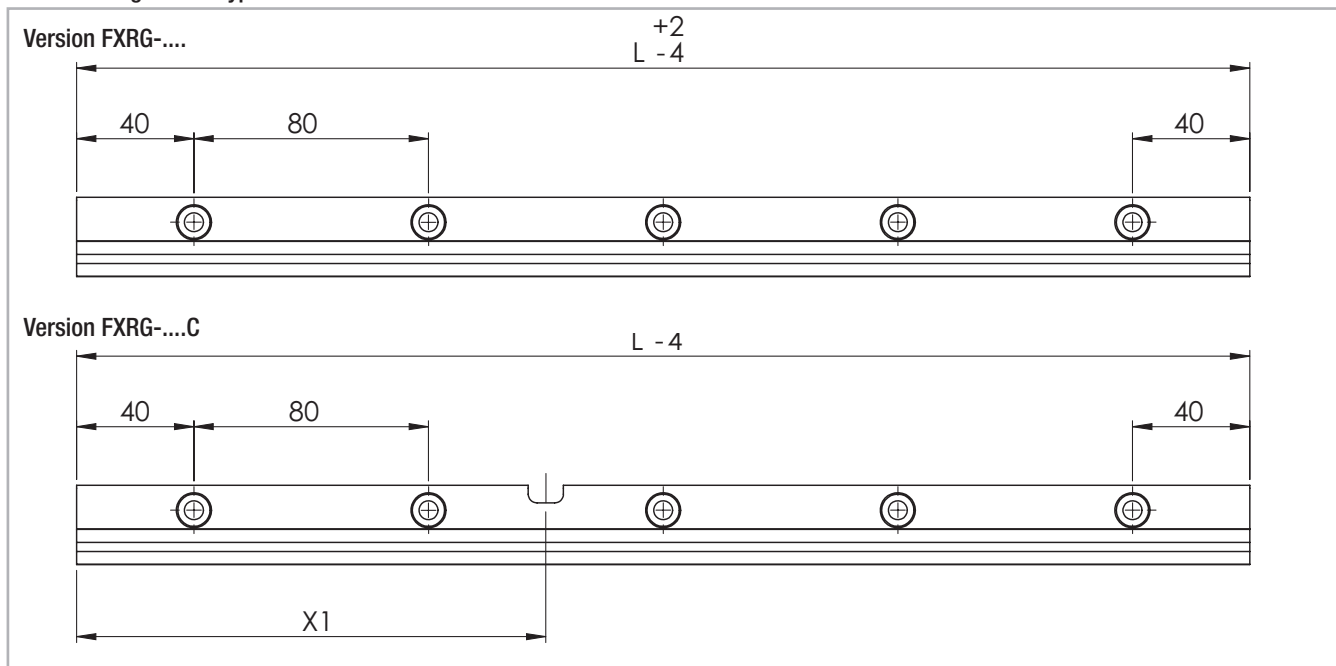

Version FXRG-.... and Version FXRG-....C with additional slot - see page OR-9

Fig. 15

Dimensions

Rail codes	Length L [mm]
<b>FXRG</b>	400 - 480 - 560 - 640 - 720 - 800 - 880 - 960 - 1040 - 1120 - 1200 - 1280 - 1360 - 1440 - 1520 - 1600 - 1680 - 1760 - 1840 - 1920 - <b>2000</b> - 2080 - 2160 - 2240 - 2320 - 2400 - 2480 - 2560 - 2640 - 2720 - 2800 - 2880 - 2960 - 3040 - 3120 - 3200 - 3280 - 3360 - 3440 - 3520 - 3600 - 3680 - 3760 - 3840 - 3920 - <b>4000</b>

Special lengths or pitches available upon request, please contact our Technical Department  
 Highlighted rail lengths are available from stock

Tab. 4

Version	Characteristics
BASIC	Cold drawn profile with high depth nitrate hardening "Rollon-Nox", oxidation with micro oil impregnation. Ends are cut to size after treatments and sprayed with protective black paint.

Tab. 5



# Accessories



## > Rollers for FXRG

### Guiding roller R.VG and floating roller R.PG

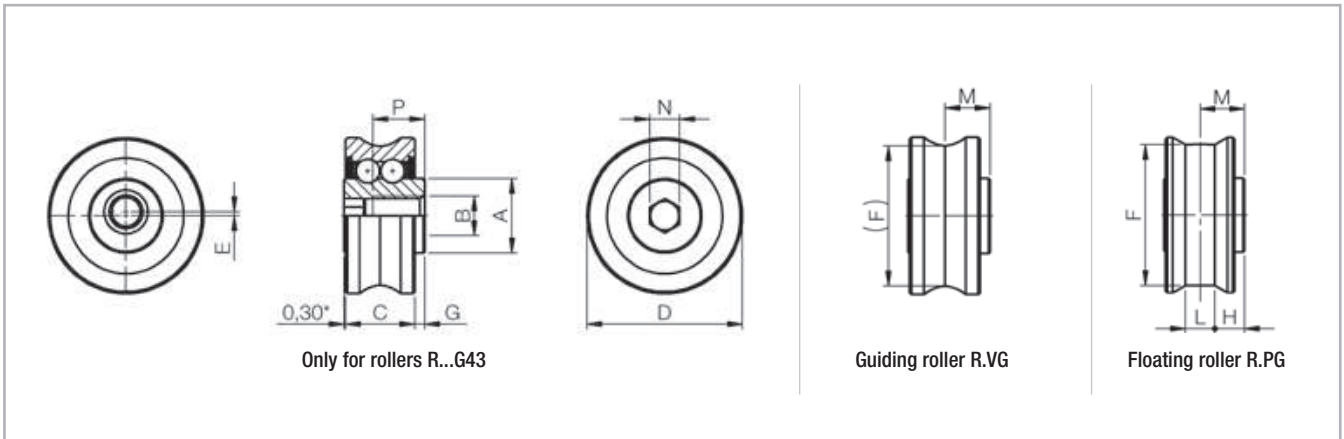

Fig. 16

Roller code	Type	Versions	E [mm]	D [mm]	C [mm]	M [mm]	G [mm]	N Key	A [mm]	B [mm]	P [mm]	F [mm]	L [mm]	H [mm]	Weight [g]	Dynamic coefficient C [N]	Load capacity	
																	Co <sub>rad</sub> [N]	Co <sub>ax</sub> [N]
RNVG43	Concentric	guiding	-	31.4	14	9	2	6	15	M8	10.5	-	-	-	50	7600	4000	1190
RNPG43		floating	-	31.5								28.59	6	6		7600	4000	0
RAVG43	Eccentric	guiding	0.8	31.4	14	9	2	6	15	M8	10.5	-	-	-	50	7600	4000	1190
RAPG43		floating		31.5								28.59	6	6		7600	4000	0

Tab. 6

### Self-aligning combinations

When FXRG rails are used in parallel, the use of floating rollers R.PG43 and guiding rollers R.VG43 provides a Self-aligning system, capable of compensating great inaccuracies of structure or assembly errors. The guiding rollers R.VG43 in contact with the FXRG's gothic raceways assure

precise guiding while compensating misalignment, as they are able to rotate slightly around the longitudinal axis of about +/- 5°. Combined with floating rollers R.PG43 on a parallel rail, such system can compensate an axial displacement of +/- 1 mm, in addition to a max. rotation of +/- 5°.

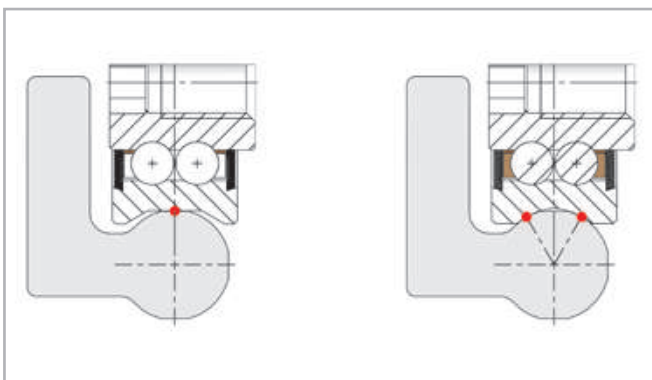

Fig. 17

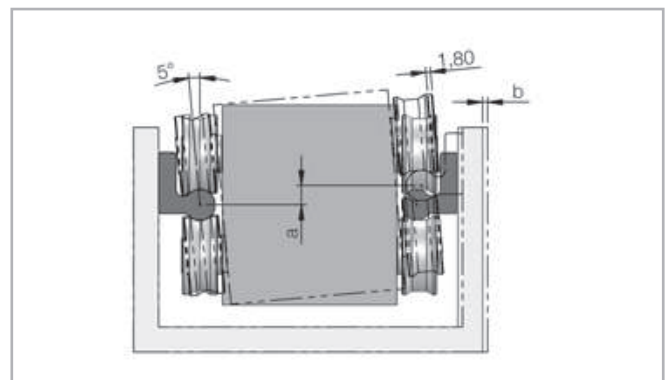

Fig. 18

## Technical instructions



### > Mounting configurations

The concentric rollers should be positioned in the direction of radial loading. Warning! A single slider configuration will rotate  $\pm 5^\circ$  around the longitudinal axis of a single FXRG rail, not able to take any  $M_x$  moments.

#### Single rail with 3 rollers slider

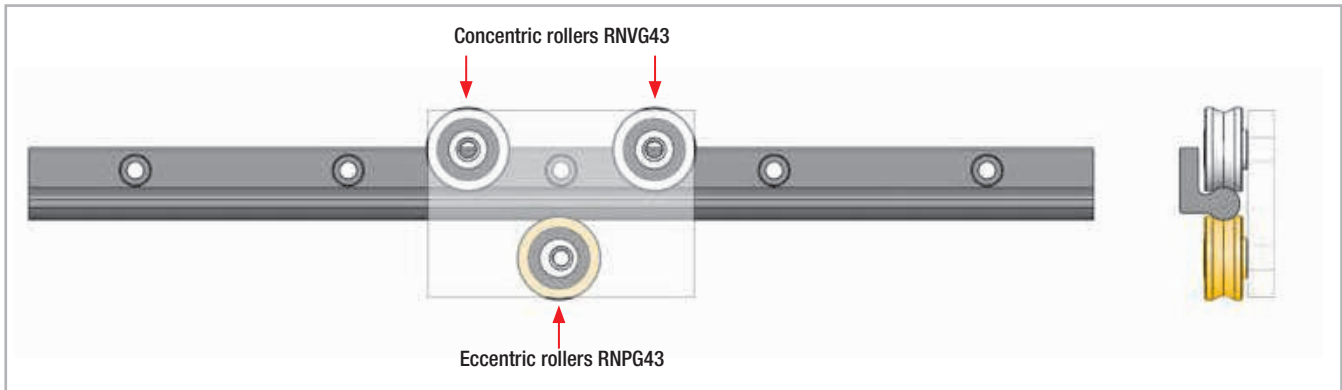

Fig. 19

It is recommended, when more than two rollers are on the same track with max. radial load, to use only two concentric rollers (as from example figure). The others should be eccentric. For cases with a wider distance between concentric rollers, please contact ROLLON's Technical department for dimensioning.

#### Single rail with 5 rollers slider

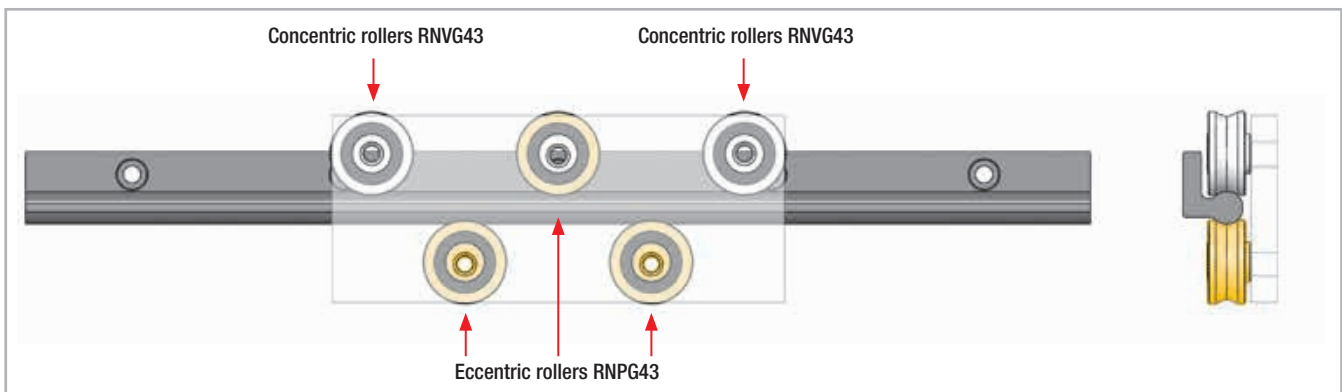

Fig. 20

#### Double rail with slider for high overturning moments

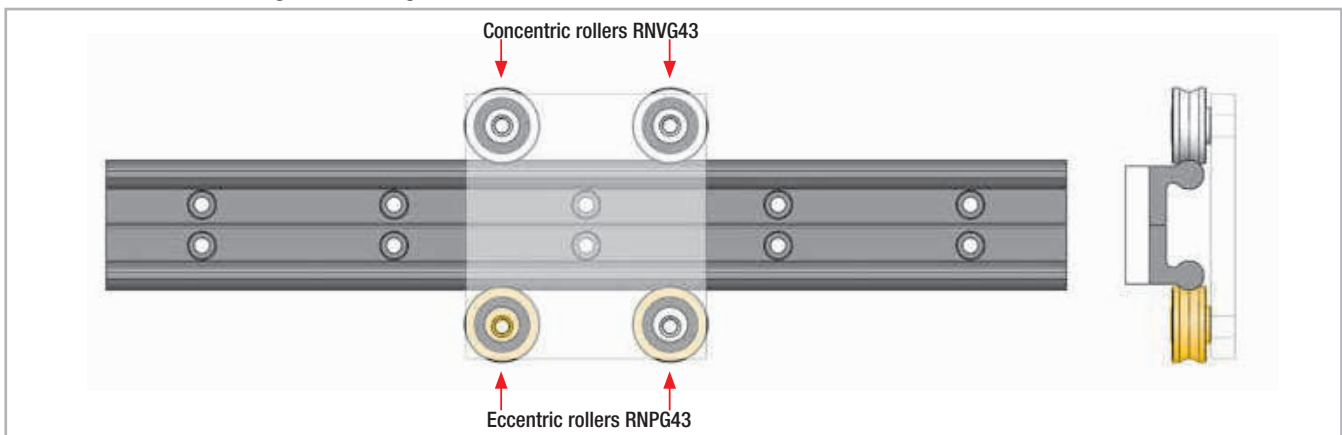

Fig. 21

The rollers need to be positioned on the rail in numbers and directions according to the prevailing load. It is always preferable to orient the rollers so that the prevailing load acts radially, due to higher radial load capacity.

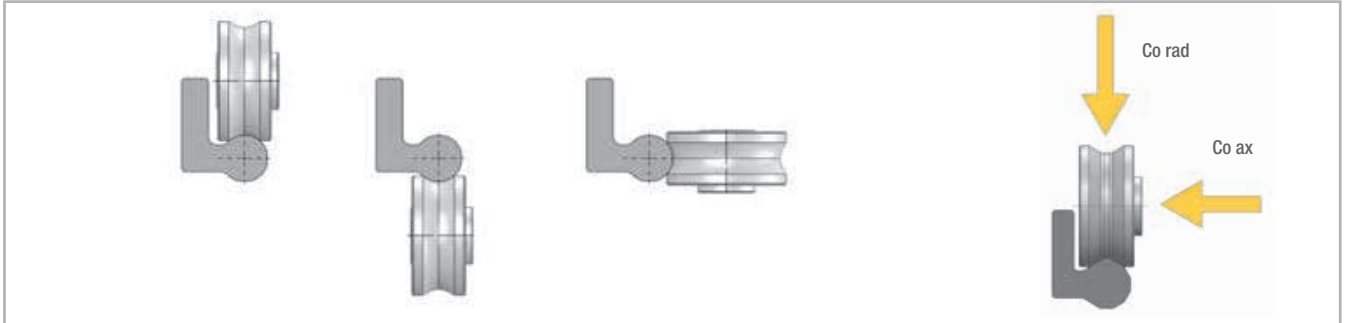

Fig.22

The rollers must be fixed on a metal surface not yielding, perfectly flat and with its fixing screws, applying a locking torque of 22 Nm.

The tightening of the fixing-screw is to be performed, while holding the roller firm with an Allen-wrench, present on the opposite side of the fixing thread. In case eccentric rollers, it is advisable to use a cup-spring washer under the screw-head to obtain a firm movement, able to maintain the roller "firm" against the surface and facilitate minor

adjustment of eccentric roller, before the final locking. The preload adjustment can also be carried out by checking the force  $F_i$  of insertion of the movable part, in which the rollers are fixed into the rail. In general for a good  $F_i$  adjustment, the inserting friction must be between 2-10 N. To increase or decrease the  $F_i$  act on eccentric rollers, opposite to the load direction (see figure below).

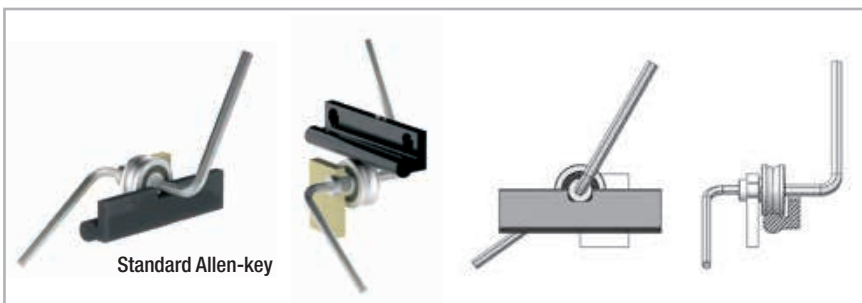
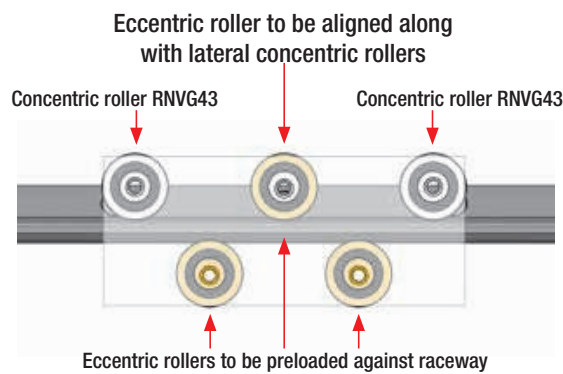

Fig. 23

In case required to have eccentric rollers on the internal rail side, it is necessary to include optional accesses, code FXRG-...C, to allow Allen-key to reach the roller. Otherwise the adjustment can take place outside of the rail.



Fig. 24  
OR-9

## > Lubrication

### Roller pin lubrication

The bearings inside the Rollers are lubricated for life. To reach the calculated service life, a film of lubricant should always be present between

the raceway and roller, this also serves to protect against corrosion of the ground raceways.

### Lubrication of the raceways

Proper lubrication during normal conditions:

- reduces friction
- reduces wear
- reduces the load of the contact surfaces through elastic deformations
- reduces running noise

## > Joined Rails

If long guide rails are required, two or more rails can be joined to the desired length. When putting guide rails together, be sure that the register marks shown in fig. 25 are positioned correctly.

These are fabricated asymmetric for parallel application of joined guide rails, unless otherwise specified.

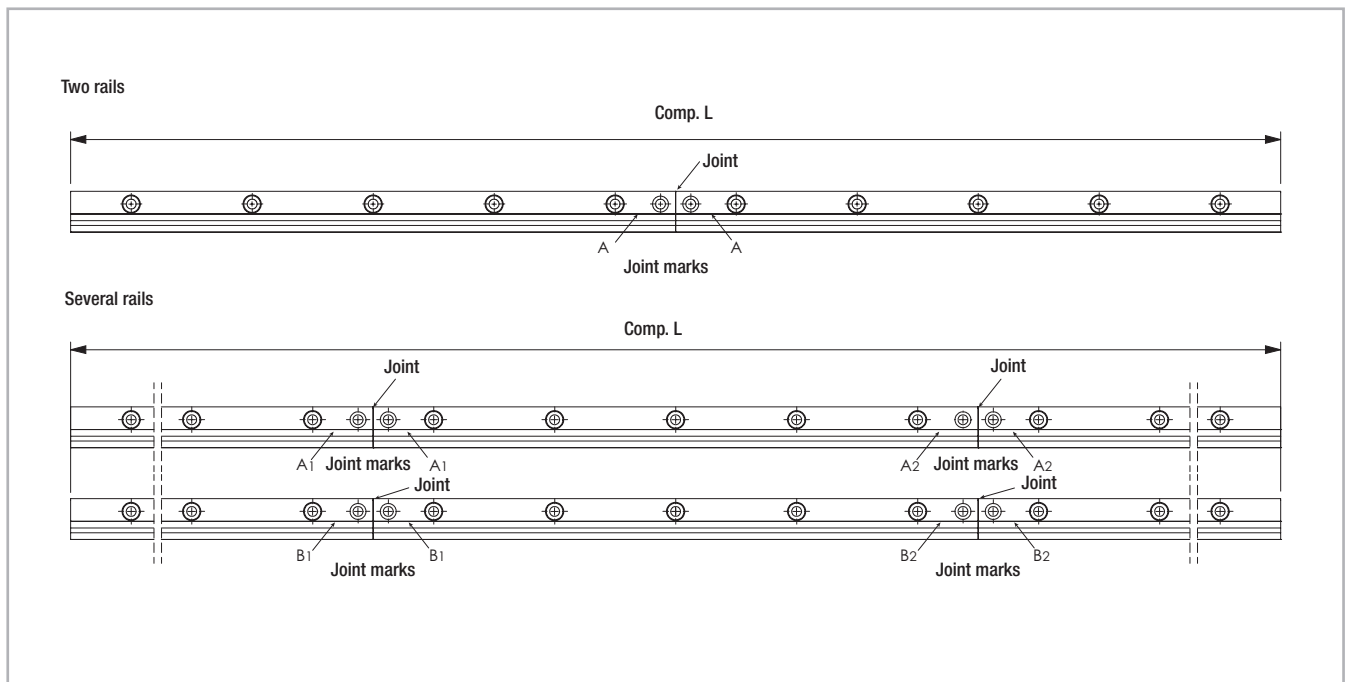

Fig. 25

### General information

The maximum available rail length in one piece is indicated in table 4 on page OR-6. Longer lengths are achieved by joining two or more rails (joined rails).

Rollon then machines the rail ends at a right angle to the impact surfaces and marks them. Two additional threaded holes (see fig. 26) are required in the load-bearing structure. To ensure a problem-free transition of the slider over the joints, please follow the installation procedures next page. For information about the structure holes, the additional screws required and the alignment fixture for aligning the rail joint, please see table 7 below.

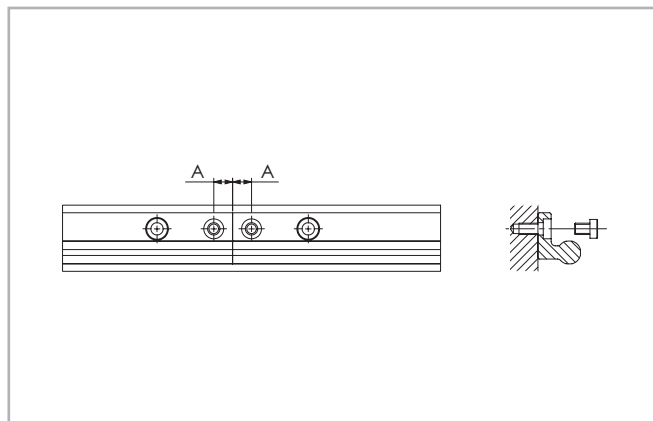

Fig. 26

Rail type	A [mm]	Threaded hole (load-bearing structure)	Screw type	Alignment fixture
FXRG	10	M6	M6 DIN 7984	ATFXR

Tab. 7

## > Installation of joined rails

After the fixing holes for the rails are made in the load-bearing structure, the joined rails can be installed according to the following procedure:

- (1) Fix the individual rails on the mounting surface by tightening all screws except for each last one on the rail joint.
- (2) Install the end fixing screws without tightening them (see fig. 27).

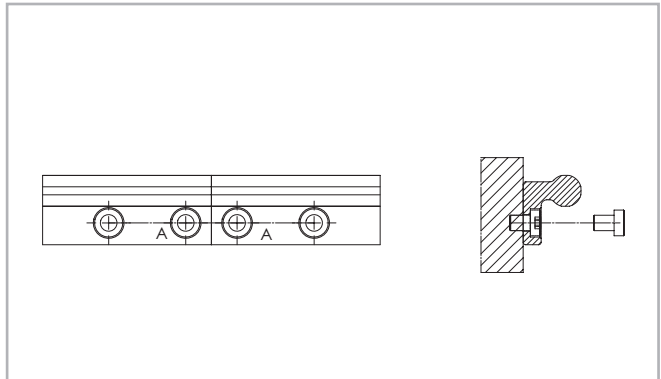

Fig. 27

- (3) Place the alignment fixture on the rail joint and tighten both set screws uniformly, until the raceways are aligned (see fig. 28).
- (4) After the previous step (3) it must be checked if both rail backs lie evenly on the mounting surface. If a gap has formed there, this must be shimmed.

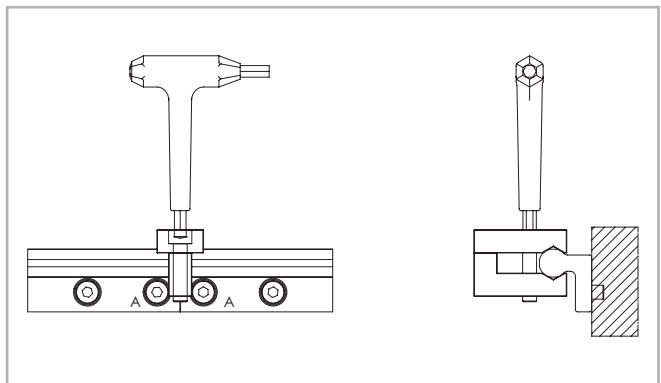

Fig. 28

- (5) The bottom of the rails should be supported in the area of the transition. Here a possible existing gap must be looked for, which must be closed if necessary for correct support of the rail ends by shims.
- (6) Insert the key through the holes in the alignment fixture and tighten the screws on the rail ends.
- (7) Remove the alignment fixture from the rail.

## Ordering key



### > O-Rail guide

FXRG

0960

Length *see pg. OR-6ff*Product type *see pg. OR-2ff*

Ordering example: FXRG-3120

Notes on ordering: Rail lengths and stroke lengths are always stated with 4 digits. Please pad with zeroes to fill in for lengths with less than 4 digits, e.g. 515mm length is "0515"