



克普典科技股份有限公司  
Captain Science Corporation

---

[www.capind.com.tw](http://www.capind.com.tw)

## 聯絡方式

[citb@ms11.hinet.net](mailto:citb@ms11.hinet.net)

Line ID : @vsh6593b



### 北區

地址：10057台北市中正區信義路二段61號2樓

電話：(02) 2351-7107 轉 16 或 1

傳真：(02) 2396-4950

### 中、南區

地址：台中市神岡區中山路667巷26弄18號

電話：(04) 2561-0236 轉 11 或 18

傳真：(04) 2561-0010

## Uniline A series



### > Uniline A series description



Fig. 1

Uniline is a family of ready-to-install linear actuators. They consist of internal Compact Rail roller sliders and steel-reinforced polyurethane belts in a rigid aluminum profile. Longitudinal seals enclose the system. This arrangement provides the best protection for the actuator from soiling and damage. In the A series, the fixed bearing rail (T-rail) is mounted horizontally in the aluminum profile. Versions with long (L) or double (D) sliders in one axis are possible.

#### The most important characteristics:

- Compact design
- Protected internal linear guides
- High traversing speeds
- Grease-free operation possible (depending on the application. For further information, please contact our Application Engineering department)
- High versatility
- Long strokes
- Versions with long or multiple sliders available in one linear axis

#### Preferred areas of application:

- Handling and automation
- Multi-axis gantries
- Packaging machines
- Cutting machines
- Displaceable panels
- Painting installations
- Welding robots
- Special machines

#### Technical data:

- Available sizes [mm]:  
Type A: 40, 55, 75
- Length and stroke tolerances:  
For strokes <1 m: +0 mm to +10 mm (+0 in to 0.4 in)  
For strokes >1 m: +0 mm to +15 mm (+0 in to 0.59 in)

## > The components

### Extruded profile

The anodized 6060 aluminum alloy extrusion used for the profile of the Rollon Uniline A series linear units were designed and manufactured by industry experts to optimize weight while maintaining mechanical strength. (see physical-chemical characteristics below). The dimensional tolerances comply with EN 755-9 standard.

### Driving belt

The Rollon Uniline A series linear units use steel reinforced polyurethane drive belts with RPP pitch and parabolic profiles. This belt is ideal due to its high load transmission characteristics, compact size and low noise. Used in conjunction with a backlash-free pulley, smooth alternating motion can

be achieved. Optimization of the maximum belt width/body dimension ratio enables the following performance characteristics to be achieved:

- High speed
- Low noise
- Low wear

### Carriage

The carriage of the Rollon Uniline A series linear units are made entirely of anodized aluminum. Each carriage has mounting T-slots for the connection to the moving element (size 40 has threaded holes). Rollon offers multiple carriages to accommodate a vast array of applications.

### General data about aluminum used: AL 6060

Chemical composition [%]

Al	Mg	Si	Fe	Mn	Zn	Cu	Impurites
Remaining	0.35-0.60	0.30-0.60	0.30	0.10	0.10	0.10	0.05-0.15

Tab. 1

Physical characteristics

Density	Coeff. of elasticity	Coeff. of thermal expansion (20°-100°C)	Thermal conductivity (20°C)	Specific heat (0°-100°C)	Resistivity	Melting point
$\frac{\text{kg}}{\text{dm}^3}$	$\frac{\text{kN}}{\text{mm}^2}$	$\frac{10^{-6}}{\text{K}}$	$\frac{\text{W}}{\text{m} \cdot \text{K}}$	$\frac{\text{J}}{\text{kg} \cdot \text{K}}$	$\Omega \cdot \text{m} \cdot 10^{-9}$	°C
2.7	69	23	200	880-900	33	600-655

Tab. 2

Mechanical characteristics

Rm	Rp (02)	A	HB
$\frac{\text{N}}{\text{mm}^2}$	$\frac{\text{N}}{\text{mm}^2}$	%	—
205	165	10	60-80

Tab. 3

> A40

A40 system

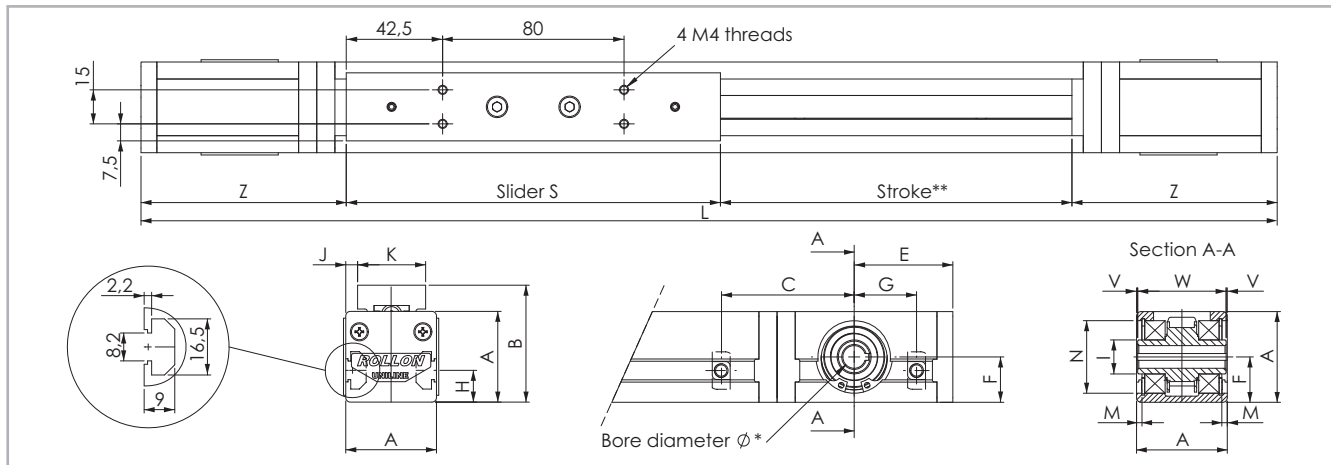

\* For information on the motor connection bores, see ordering key. \*\* The length of the safety stroke is provided on request according to the customer's specific requirements.

Fig. 2

Type	A [mm]	B [mm]	C* [mm]	E [mm]	F [mm]	G* [mm]	H [mm]	I [mm]	J [mm]	K [mm]	M [mm]	N [mm]	S [mm]	V [mm]	W [mm]	Z [mm]	Stroke** [mm]
A40	40	51.5	57	43.5	20	26	14	∅ 14,9	5	30	2.3	∅ 32	165	0.5	39	91.5	1900

\* For the position of the T-nuts when using our motor adapter plates, see pg. US-11ff

\*\* Maximum stroke for a single-piece guiding rail. For longer strokes, see tab. 9

Tab. 4

A40L with long slider

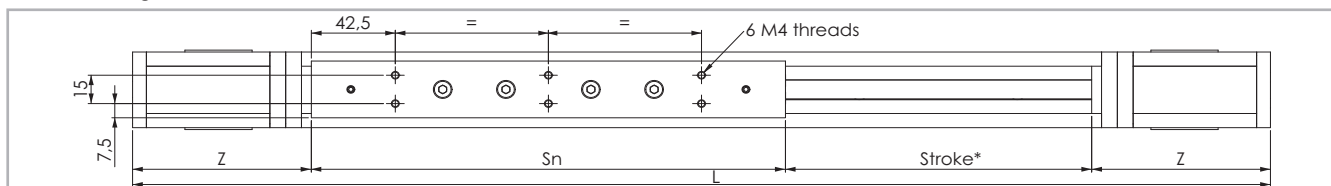

\* The length of the safety stroke is provided on request according to the customer's specific requirements.

Fig. 3

Type	S <sub>min</sub> [mm]	S <sub>max</sub> [mm]	Sn [mm]	Z [mm]	Stroke* [mm]
A40L	240	400	$S_n = S_{min} + n \cdot 10$	91.5	1660

\* Maximum stroke for a single-piece guiding rail and a maximum slider plate length S<sub>max</sub>. For longer strokes, see tab. 9

Tab. 5

A40D with double slider

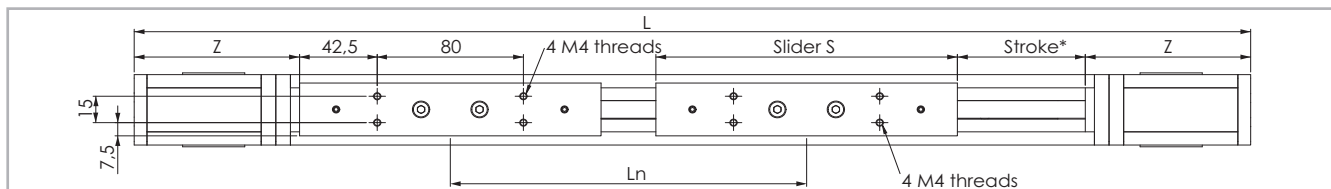

\* The length of the safety stroke is provided on request according to the customer's specific requirements.

Fig. 4

Type	S [mm]	L <sub>min</sub> [mm]	L <sub>max</sub> ** [mm]	Ln [mm]	Z [mm]	Stroke* [mm]
A40D	165	235	1900	$L_n = L_{min} + n \cdot 5$	91.5	1660

\* Maximum stroke for a single-piece guiding rail and a minimum slider plate distance L<sub>min</sub>

\*\* Maximum distance L<sub>max</sub> between the centres of slider plates at a stroke of 0 mm

For longer strokes, see tab. 9

Tab. 6

> Load ratings, moments and characteristic data

A40

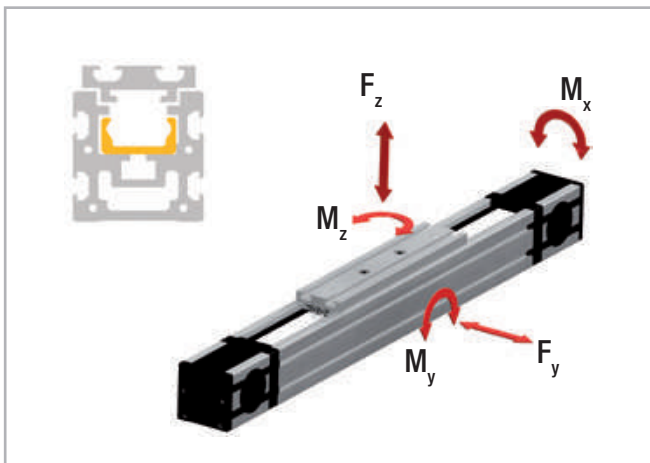

Fig. 5

Driving belt

The driving belt is manufactured from a friction resistant polyurethane and with steel cords for high tensile stress resistance.

Type	Type of belt	Belt width [mm]	Weight [kg/m]
A40	10RPP5	10	0.041

Tab. 7

Belt length (mm) = 2 x L - 168 Standard slider

Belt length (mm) = 2 x L - S<sub>n</sub>-3 Long slider

Belt length (mm) = 2 x L - L<sub>n</sub> - 168 Double slider

Type	C [N]	F <sub>y</sub> [N]	F <sub>z</sub> [N]	M <sub>x</sub> [Nm]	M <sub>y</sub> [Nm]	M <sub>z</sub> [Nm]
A40	1530	820	300	2.8	5.6	13.1
A40-L	3060	1640	600	5.6	22 to 70	61 to 192
A40-D	3060	1640	600	5.6	70 to 570	193 to 1558

For the calculation of the allowed moments, please observe pages SL-5ff

Tab. 8

Technical data	Type
	A40
Standard belt tension [N]	160
Moment at no load [Nm]	0.14
Max. traversing speed [m/s]	3
Max. acceleration [m/s <sup>2</sup> ]	10
Repeat accuracy [mm]	0.1
Compact Rail guiding rail	TLV18
Slider type	CS18 spec.
Moment of inertia I <sub>y</sub> [cm <sup>4</sup> ]	12
Moment of inertia I <sub>z</sub> [cm <sup>4</sup> ]	13.6
Pitch diameter of pulley [m]	0.02706
Moment of inertia of each pulley [gmm <sup>2</sup> ]	5055
Stroke per shaft revolution [mm]	85
Mass of slider [g]	220
Weight with zero stroke [g]	1459
Weight with 1 m stroke [g]	3465
Max. stroke [mm]	3500
Working temperature	from -20 °C to + 80 °C

Tab. 9

> A55

A55 system

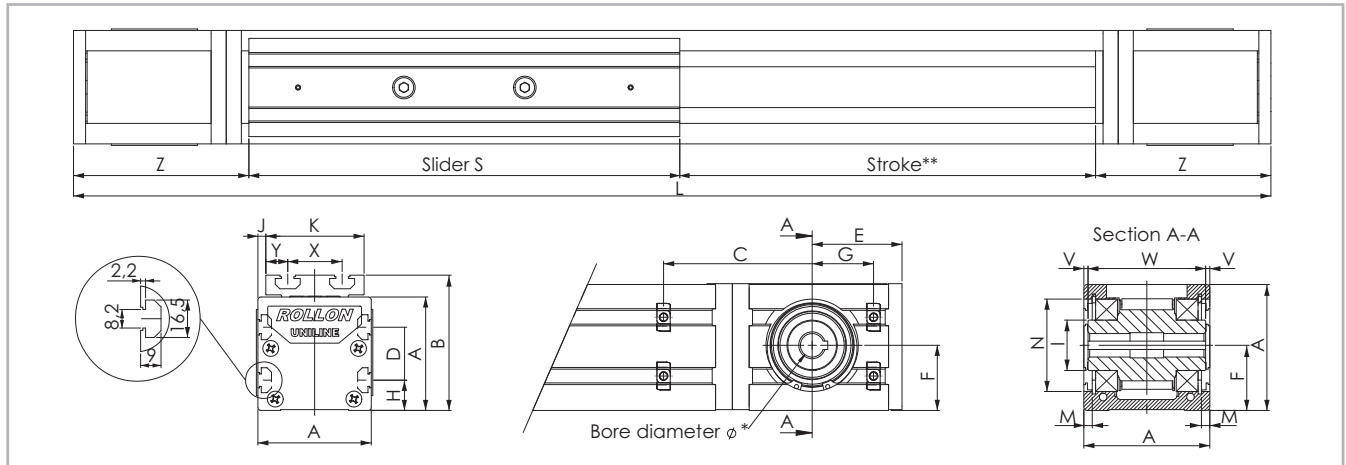

\* For information on the motor connection bores, see ordering key. \*\* The length of the safety stroke is provided on request according to the customer's specific requirements. Fig. 6

Type	A [mm]	B [mm]	C* [mm]	D [mm]	E [mm]	F [mm]	G* [mm]	H [mm]	I [mm]	J [mm]	K [mm]	M [mm]	N [mm]	S [mm]	X [mm]	Y [mm]	V [mm]	W [mm]	Z [mm]	Stroke** [mm]
A55	55	71	67.5	25	50.5	27.5	32.5	15	∅ 24.9	1.5	52	2.35	∅ 47	200	28	12	0.5	54	108	3070

\* For the position of the T-nuts when using our motor adapter plates, see pg. US-11ff Tab. 10  
 \*\* Maximum stroke for a single-piece guiding rail. For longer strokes, see tab. 15

A55L with long slider

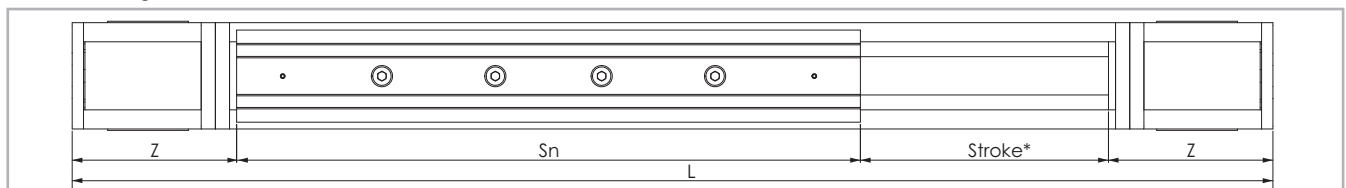

\* The length of the safety stroke is provided on request according to the customer's specific requirements. Fig. 7

Type	S <sub>min</sub> [mm]	S <sub>max</sub> [mm]	Sn [mm]	Z [mm]	Stroke* [mm]
A055-L	310	500	$Sn = S_{min} + n \cdot 10$	108	2770

\* Maximum stroke for a single-piece guiding rail and a maximum slider plate length S<sub>max</sub> Tab. 11  
 For longer strokes, see tab. 15

A55D with double slider

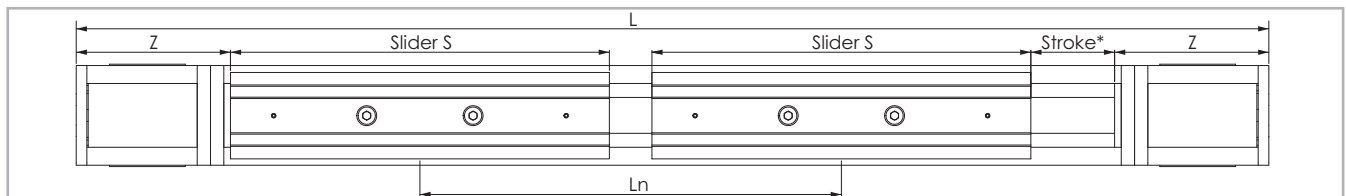

\* The length of the safety stroke is provided on request according to the customer's specific requirements. Fig. 8

Type	S [mm]	L <sub>min</sub> [mm]	L <sub>max</sub> ** [mm]	Ln [mm]	Z [mm]	Stroke* [mm]
A55D	200	300	3070	$Ln = L_{min} + n \cdot 5$	108	2770

\* Maximum stroke for a single-piece guiding rail and a minimum slider plate distance L<sub>min</sub> Tab. 12  
 \*\* Maximum distance L<sub>max</sub> between the centres of slider plates at a stroke of 0 mm  
 For longer strokes, see tab. 15

> Load ratings, moments and characteristic data

A55

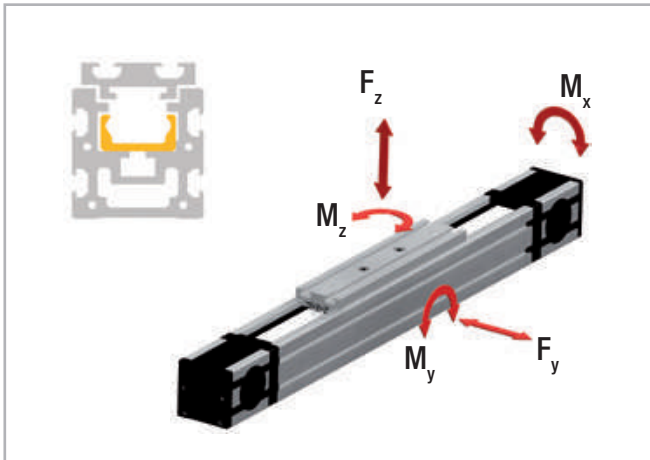

Fig. 9

Driving belt

The driving belt is manufactured from a friction resistant polyurethane and with steel cords for high tensile stress resistance.

Type	Type of belt	Belt width [mm]	Weight [kg/m]
A55	18RPP5	18	0.074

Tab. 13

Belt length (mm) = 2 x L - 182 Standard slider

Belt length (mm) = 2 x L - S<sub>n</sub>+18 Long slider

Belt length (mm) = 2 x L - L<sub>n</sub> - 182 Double slider

Type	C [N]	F <sub>y</sub> [N]	F <sub>z</sub> [N]	M <sub>x</sub> [Nm]	M <sub>y</sub> [Nm]	M <sub>z</sub> [Nm]
A55	4260	2175	750	11.5	21.7	54.4
A55-L	8520	4350	1500	23	82 to 225	239 to 652
A55-D	8520	4350	1500	23	225 to 2302	652 to 6677

For the calculation of the allowed moments, please observe pages SL-5ff

Tab. 14

Technical data	Type
	A55
Standard belt tension [N]	220
Moment at no load [Nm]	0.22
Max. traversing speed [m/s]	5
Max. acceleration [m/s <sup>2</sup> ]	15
Repeat accuracy [mm]	0.1
Compact Rail guiding rail	TLV28
Slider type	CS28 spec.
Moment of inertia I <sub>y</sub> [cm <sup>4</sup> ]	34.6
Moment of inertia I <sub>z</sub> [cm <sup>4</sup> ]	41.7
Pitch diameter of pulley [m]	0.04138
Moment of inertia of each pulley [gmm <sup>2</sup> ]	45633
Stroke per shaft revolution [mm]	130
Mass of slider [g]	475
Weight with zero stroke [g]	2897
Weight with 1 m stroke [g]	4505
Max. stroke [mm]	5500
Working temperature	from -20 °C to + 80 °C

Tab. 15

> A75

A75 system

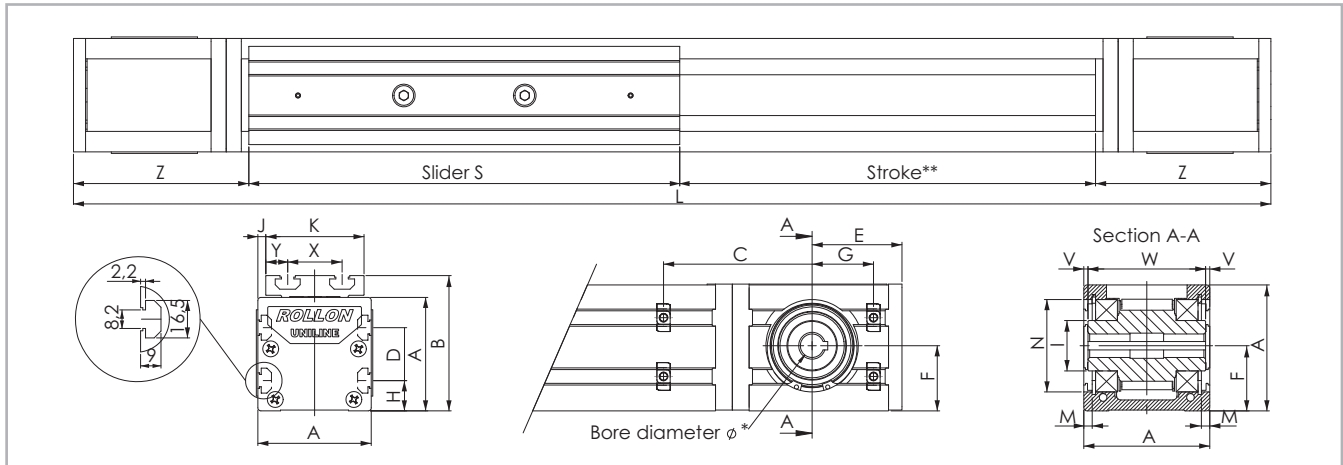

\* For information on the motor connection bores, see ordering key. \*\* The length of the safety stroke is provided on request according to the customer's specific requirements. Fig. 10

Type	A [mm]	B [mm]	C* [mm]	D [mm]	E [mm]	F [mm]	G* [mm]	H [mm]	I [mm]	J [mm]	K [mm]	M [mm]	N [mm]	S [mm]	X [mm]	Y [mm]	V [mm]	W [mm]	Z [mm]	Stroke** [mm]
A75	75	90	71.5	35	53.5	38.8	34.5	20	∅ 29.5	5	65	4.85	∅ 55	285	36	14.5	2.3	70.4	116	3420

\* For the position of the T-nuts when using our motor adapter plates, see pg. US-11ff  
 \*\* Maximum stroke for a single-piece guiding rail. For longer strokes, see tab. 21 Tab. 16

A75L with long slider

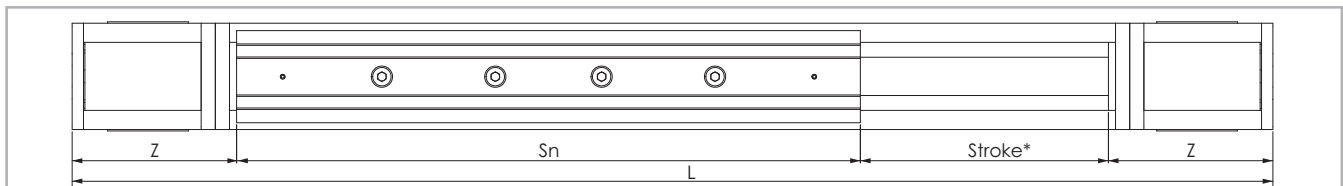

\* The length of the safety stroke is provided on request according to the customer's specific requirements. Fig. 11

Type	S <sub>min</sub> [mm]	S <sub>max</sub> [mm]	Sn [mm]	Z [mm]	Stroke* [mm]
A75-L	440	700	$S_n = S_{min} + n \cdot 10$	116	3000

\* Maximum stroke for a single-piece guiding rail and a maximum slider plate length S<sub>max</sub>  
 For longer strokes, see tab. 21 Tab. 17

A75D with double slider

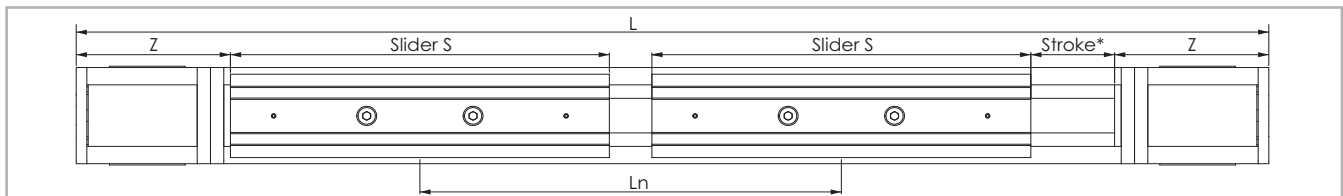

\* The length of the safety stroke is provided on request according to the customer's specific requirements. Fig. 12

Type	S [mm]	L <sub>min</sub> [mm]	L <sub>max</sub> ** [mm]	Ln [mm]	Z [mm]	Stroke* [mm]
A75D	285	416	3416	$L_n = L_{min} + n \cdot 8$	116	3000

\* Maximum stroke for a single-piece guiding rail and a minimum slider plate distance L<sub>min</sub>  
 \*\* Maximum distance L<sub>max</sub> between the centres of slider plates at a stroke of 0 mm  
 For longer strokes, see tab. 21 Tab. 18



## > Load ratings, moments and characteristic data

A75

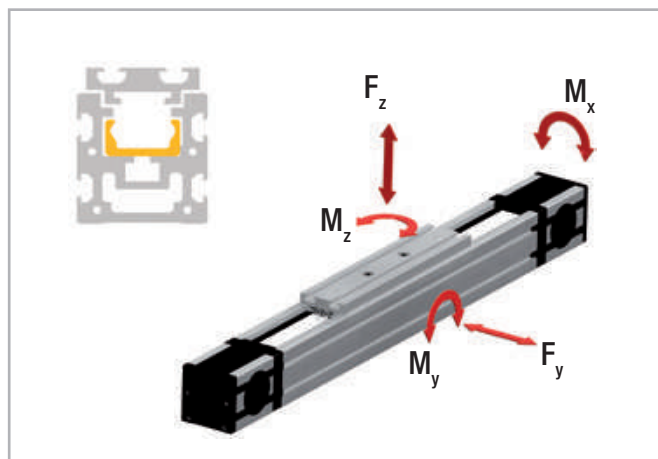

Fig. 13

### Driving belt

The driving belt is manufactured from a friction resistant polyurethane and with steel cords for high tensile stress resistance.

Type	Type of belt	Belt width [mm]	Weight [kg/m]
A75	30RPP8	30	0.185

Tab. 19

**Belt length (mm)** = 2 x L - 213 Standard slider

**Belt length (mm)** = 2 x L - S<sub>n</sub>+72 Long slider

**Belt length (mm)** = 2 x L - L<sub>n</sub> - 213 Double slider

Type	C [N]	F <sub>y</sub> [N]	F <sub>z</sub> [N]	M <sub>x</sub> [Nm]	M <sub>y</sub> [Nm]	M <sub>z</sub> [Nm]
A75	12280	5500	1855	43.6	81.5	209
A75-L	24560	11000	3710	87.2	287 to 770	852 to 2282
A75-D	24560	11000	3710	87.2	771 to 6336	2288 to 18788

For the calculation of the allowed moments, please observe pages SL-5ff

Tab. 20

Technical data	Type
	A75
Standard belt tension [N]	800
Moment at no load [Nm]	1.15
Max. traversing speed [m/s]	7
Max. acceleration [m/s <sup>2</sup> ]	15
Repeat accuracy [mm]	0.1
Compact Rail guiding rail	TLV43
Slider type	CS43 spec.
Moment of inertia I <sub>y</sub> [cm <sup>4</sup> ]	127
Moment of inertia I <sub>z</sub> [cm <sup>4</sup> ]	172
Pitch diameter of pulley [m]	0.05093
Moment of inertia of each pulley [gmm <sup>2</sup> ]	139969
Stroke per shaft revolution [mm]	160
Mass of slider [g]	1242
Weight with zero stroke [g]	6729
Weight with 1 m stroke [g]	9751
Max. stroke [mm]	7500
Working temperature	from -20 °C to + 80 °C

Tab. 21

## > Lubrication

The raceways of the guide rails in the Uniline linear axes are prelubricated. To achieve the calculated service life, a lubrication film must always be present between the raceway and the roller. The lubrication film also provides anticorrosion protection to the ground raceways. An approximate value for the lubrication period is every 100 km or every six months. The recommended lubricant is a lithium-based roller bearing grease of medium consistency.

### Lubrication of the raceways

Proper lubrication under normal conditions:

- reduces friction
- reduces wear
- reduces stress on the contact faces
- reduces running noise

Lubricants	Thickeners	Temperature range [°C]	Dynamic viscosity [mPas]
Roller bearing grease	Lithium soap	-30 to +170	<4500

Tab. 22

### Relubrication of the guide rails

These types of rails have a lubricating conduit on the side of the slider plate through which the lubricant can be applied directly to the raceways. Lubrication can be done in one of two ways:

#### 1. Relubrication using a grease gun:

This is done by inserting the tip of the grease gun into the conduit at the slider plate and injecting the grease inside (see fig. 14). Please note that the grease has to fill the whole conduit in order to lubricate the rail properly; for this reason sufficient grease must be used.

#### 2. Automatic lubrication system:

To connect the unit to an automatic greasing system, use a proper adapter/connector\* that attaches to the threaded hole on the side of the trolley. The advantage of this solution is the possibility of rail re-lubrication with-

out machine downtime.

\*(Any adapter that may be necessary must be manufactured on site)

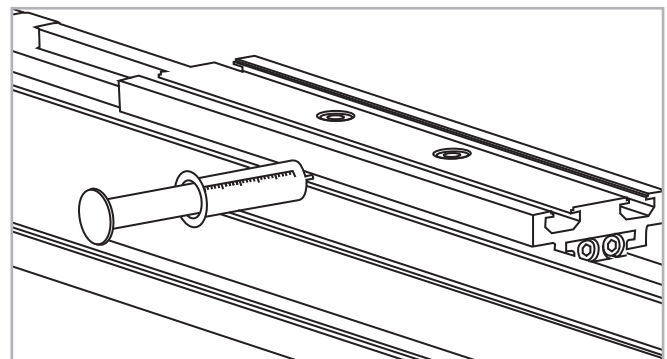

Fig. 14

### Cleaning the guide rails

It is always recommended to clean the slider rail prior to any relubrication, in order to remove grease residues. This can be done while performing maintenance work or during a scheduled machine stop.

1. Unscrew the safety screws C (on top of the slider plate) from the belt tensioning device A (see fig. 15).
2. Also completely unscrew the belt tensioning screws B and remove the belt tensioning devices A from their housings.
3. Lift the toothed belt until the guide rails can be seen.  
Important: Ensure that the side seal is not damaged.
4. Clean the rail raceways with a clean and dry cloth. Ensure that all grease and dirt residues from previous work processes are removed.  
To ensure that the rails are cleaned over their entire length, the slider plate should be moved once over its entire length.
5. Apply a sufficient amount of grease to the raceways.

6. Re-insert the belt tensioning devices A into their housings and mount the belt tensioning screws B. Re-adjust the belt tension (see pg. US-59).

7. Fasten the safety screws C.

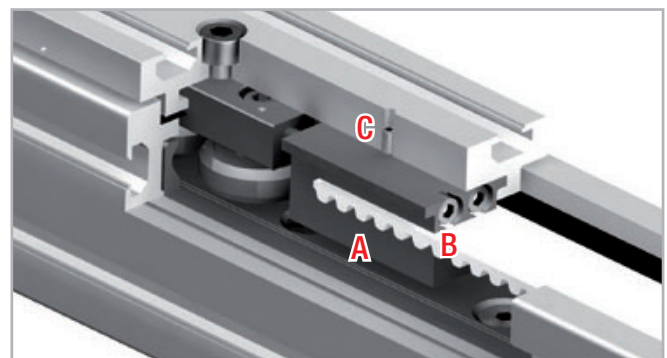

Fig. 15

## > Accessories

### Adapter plates

#### Standard motor adapter plates AC2

Mounting plates for the most common motors or gearboxes. The connection bores for the motors or gearboxes must be made on site. All plates are delivered with M6 x 10 screws to DIN 912 and T-nuts for mounting on the linear units.

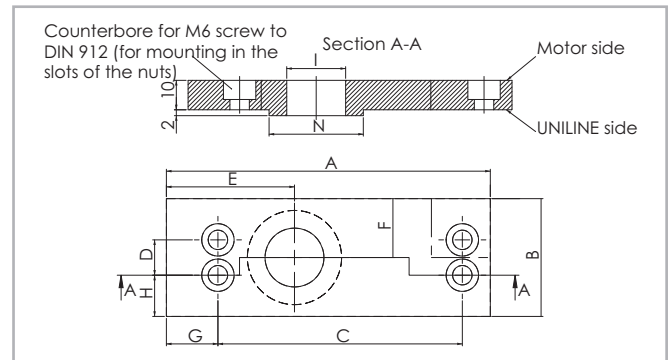

Fig. 16

Size	A [mm]	B [mm]	C [mm]	D [mm]	E [mm]	F [mm]	G [mm]	H [mm]	I [mm]	N [mm]
40	110	40	83	12	43.5	20	17.5	14	Ø 20	Ø 32
55	126	55	100	25	50.5	27.5	18	15	Ø 30	Ø 47
75	135	70	106	35	53.5	35	19	17.5	Ø 35	Ø 55

Tab. 23

#### NEMA plates AC1-P

Mounting plates for NEMA motors or gearboxes. These plates are delivered ready-to-mount on the linear axes. All plates are delivered with M6 x 10 screws to DIN 912 and T-nuts for mounting on the linear units.

Size	NEMA Motors / Gearboxes
40	NEMA 23
55	NEMA 34
75	NEMA 42

Tab. 24

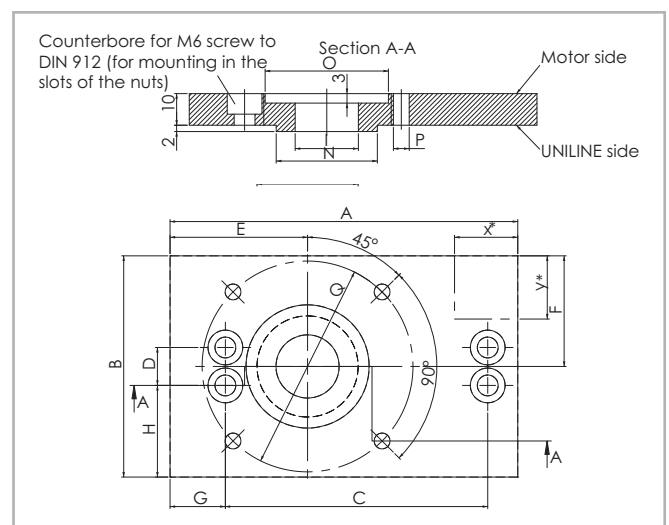

Fig. 17

Size	A [mm]	B [mm]	C [mm]	D [mm]	E [mm]	F [mm]	G [mm]	H [mm]	I [mm]	N [mm]	O [mm]	P [mm]	Q [mm]
40	110	70	83	12	43.5	35	17.5	29	20	Ø 32	Ø 39	Ø 5	Ø 66.7
55	126	100	100	25	50.5	50	18	37.5	30	Ø 47	Ø 74	Ø 5.5	Ø 98.4
75	135	120	106	35	53.5	60	19	42.5	35	Ø 55	Ø 57	Ø 7.1	Ø 125.7

Tab. 25

#### Synchronous use of linear axes in pairs

If two axes are to be used in parallel using a connecting shaft, please specify when ordering, to ensure that the key slots of the pulleys are synchronized.

**Fixing brackets APF-2**

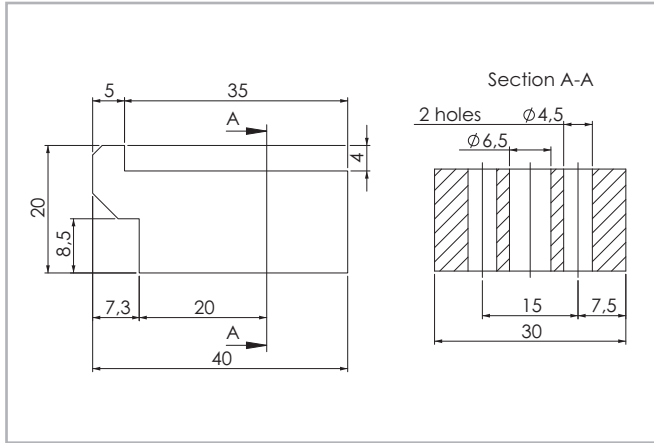

Fig. 18

Fixing clamp for simple mounting of a linear axis on a mounting surface or for connecting two units with or without a connection plate (see pg. US-63).

A spacer\* may be necessary.

\*(Any spacer that may be necessary must be manufactured on site)

**T-nut**

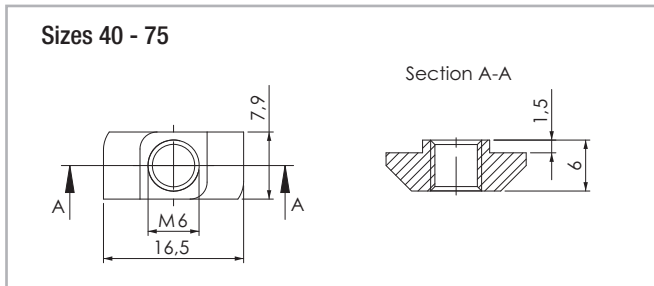

Fig. 19

The maximum tightening torque is 10 Nm.

**Assembly kits**

**T-connection plate APC-1**

T-connection plate allows two units to be mounted perpendicular to each other (see pg. US-60). The plate will not interfere with the strokes of either unit. All plates are delivered with M6 x 10 screws to DIN 912 and T-nuts for mounting on the linear units.

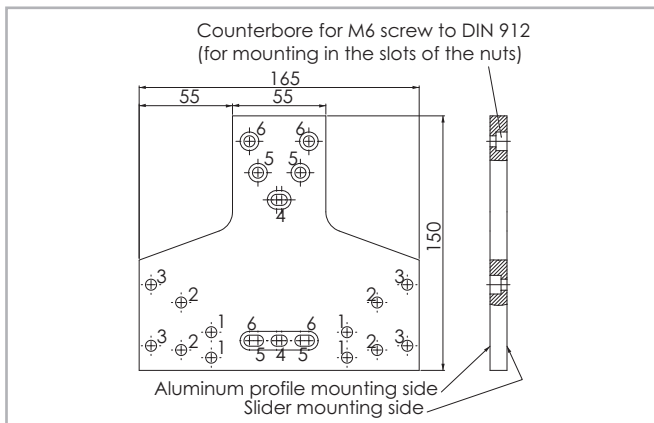

Fig. 20

**Note**

In case of use of APC-1 plates with E and ED series, please consult Rollon Technical Dpt. In standard there is an interference between U-rail and APC-1 plate. A special version with shorter U-rail at both extremities will be offered.

Size	Fixing holes for the slider	Fixing holes for the profile
40	Holes 1	Holes 4
55	Holes 2	Holes 5
75	Holes 3	Holes 6

Tab. 26

**Angle connection plate APC-2**

allows the right angle mounting of two units. The trolley of one unit can be mounted to the side of the other (see pg. US-61). The plate will not interfere with the strokes of either unit. All plates are delivered with M6 x 10 screws to DIN 912 and T-nuts for mounting to the linear units.

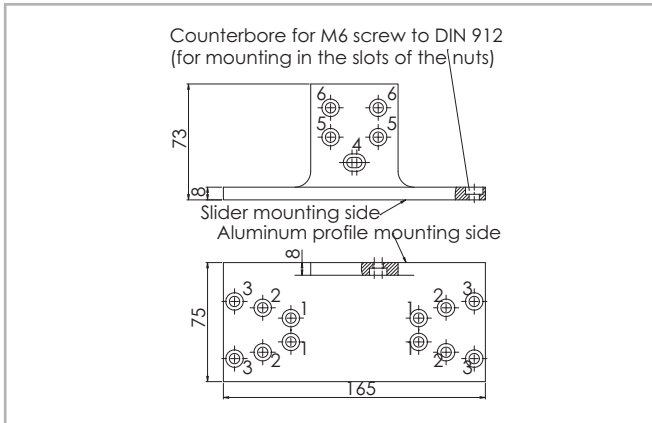

Fig. 21

Size	Fixing holes for the slider	Fixing holes for the profile
40	Holes 1	Holes 4
55	Holes 2	Holes 5
75	Holes 3	Holes 6

Tab. 27

**X connection plate APC-3**

X connection plate for mounting two sliders perpendicular to each other (see pg. US-62). The plate will not interfere with the strokes of either unit. All plates are delivered with M6 x 10 screws to DIN 912 and T-nuts for mounting on the linear units.

Size	Fixing holes for slider 1	Fixing holes for slider 2
40	Holes 1	Holes 4
55	Holes 2	Holes 5
75	Holes 3	Holes 6

Tab. 28

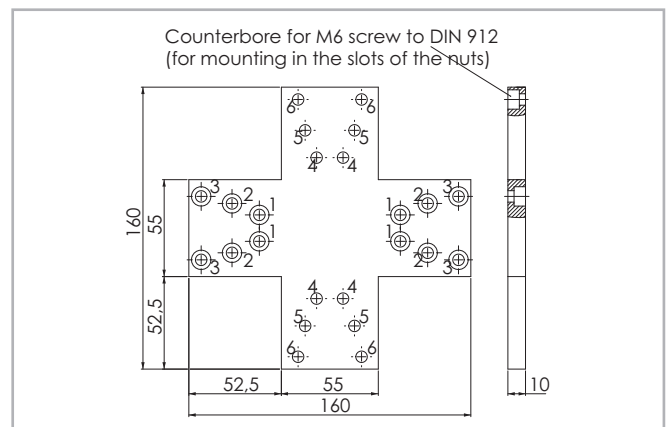

Fig. 22

**Ordering key** 

**> Identification code for Uniline linear unit**

U	A	07 04=40 05=55 07=75	1A	1190	1A	D 500	L 350
						Indices of long slider plate <i>see pg. US-4 - US-6 - US-8</i>	
						Indices of double slider plate, <i>distance of the centers of slider plates</i> <i>see pg. US-4 - US-6 - US-8</i>	
						Profile/Rail code	
						L= Total length of the unit	
						Driving head code	
						Size <i>see pg. US-4 - US-6 - US-8</i>	
						Type	
Uniline prefix							

Ordering example: UA 07 1A 1190 1A D 500 L 350

In order to create identification codes for Actuator Line, you can visit: <http://configureactuator.rollon.com>



**Left / right orientation**

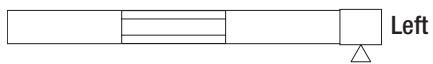

## > Accessories

### Standard motor adapter plate

A	07	AC2	Standard motor adapter plates <i>see pg. US-11</i>
	04=40		
	05=55		
	07=75		
Size		<i>see pg. US-11</i>	
Type			

Ordering example: A07-AC2

### NEMA motor adapter plates

A	07	AC1	NEMA motor adapter plates <i>see pg. US-11</i>
	04=40		
	05=55		
	07=75		
Size		<i>see pg. US-11</i>	
Type			

Ordering example: A07-AC1

**T-connection plate** Order code: APC-,1 s. pg. US-12

**Angle connection plate** Order code: APC-2, s. pg. US-13

**X connection plate** Order code: APC-3, s. pg. US-13

**Fixing clamp** Order code: APF-2, s. pg. US-12

### Motor connection bores

Hole [Ø]	Size			Head code
	40	55	75	
<b>Metric [mm]</b> with slot for key	10G8 / 3js9	12G8 / 4js9	14G8 / 5js9	1A
		10G8 / 3js9	16G8 / 5js9	2A
		14G8 / 5js9	19G8 / 6js9	3A
		16G8 / 5js9		4A
<b>Metric [mm]</b> for compression coupling			18	1B
			24	2B
<b>Inch [in]</b> with slot for key	3/8 / 1/8	1/2 / 1/8	5/8 / 3/16	1P
		3/8 / 1/8		2P
		5/8 / 3/16		3P

Tab. 29

The highlighted connection bores are standard connections

Metric: key seat for keys to DIN 6885 form A

Inch: key seat for keys to BS 46 Part 1: 1958

## Uniline C series



### > Uniline C series description



Fig. 23

Uniline is a family of ready-to-install linear actuators. They consist of internal Compact Rail roller sliders and steel-reinforced polyurethane belts in a rigid aluminum profile. Longitudinal seals enclose the system. This arrangement provides the best protection for the actuator from soiling and damage. In the C series, the fixed bearing rail (T-rail) and the compensating bearing rail (U-rail) are mounted in the aluminum profile vertically. Versions with long (L) or double (D) sliders in one axis are possible.

#### The most important characteristics:

- Compact design
- Protected internal linear guides
- High traversing speeds
- Grease-free operation possible (depending on the application. For further information, please contact our Application Engineering department)
- High versatility
- Long strokes
- Versions with long or multiple sliders available in one linear axis

#### Preferred areas of application:

- Handling and automation
- Multi-axis gantries
- Packaging machines
- Cutting machines
- Displaceable panels
- Painting installations
- Welding robots
- Special machines

#### Technical data:

- Available sizes [mm]:  
Type C: 55, 75
- Length and stroke tolerances:  
For strokes <1 m: +0 mm to +10 mm (+0 in to 0.4 in)  
For strokes >1 m: +0 mm to +15 mm (+0 in to 0.59 in)



## > The components

### Extruded profile

The anodized 6060 aluminum alloy extrusion used for the profile of the Rollon Uniline C series linear units were designed and manufactured by industry experts to optimize weight while maintaining mechanical strength. (see physical-chemical characteristics below). The dimensional tolerances comply with EN 755-9 standard.

### Driving belt

The Rollon Uniline C series linear units use steel reinforced polyurethane drive belts with RPP pitch and parabolic profiles. This belt is ideal due to its high load transmission characteristics, compact size and low noise. Used in conjunction with a backlash-free pulley, smooth alternating motion can

be achieved. Optimization of the maximum belt width/body dimension ratio enables the following performance characteristics to be achieved:

- High speed
- Low noise
- Low wear

### Carriage

The carriage of the Rollon Uniline C series linear units are made entirely of anodized aluminum. Each carriage has mounting T-slots for the connection to the moving element. Rollon offers multiple carriages to accommodate a vast array of applications.

### General data about aluminum used: AL 6060

Chemical composition [%]

Al	Mg	Si	Fe	Mn	Zn	Cu	Impurites
Remaining	0.35-0.60	0.30-0.60	0.30	0.10	0.10	0.10	0.05-0.15

Tab. 30

Physical characteristics

Density	Coeff. of elasticity	Coeff. of thermal expansion (20°-100°C)	Thermal conductivity (20°C)	Specific heat (0°-100°C)	Resistivity	Melting point
$\frac{\text{kg}}{\text{dm}^3}$	$\frac{\text{kN}}{\text{mm}^2}$	$\frac{10^{-6}}{\text{K}}$	$\frac{\text{W}}{\text{m} \cdot \text{K}}$	$\frac{\text{J}}{\text{kg} \cdot \text{K}}$	$\Omega \cdot \text{m} \cdot 10^{-9}$	°C
2.7	69	23	200	880-900	33	600-655

Tab. 31

Mechanical characteristics

Rm	Rp (02)	A	HB
$\frac{\text{N}}{\text{mm}^2}$	$\frac{\text{N}}{\text{mm}^2}$	%	—
205	165	10	60-80

Tab. 32

> C55

C55 system

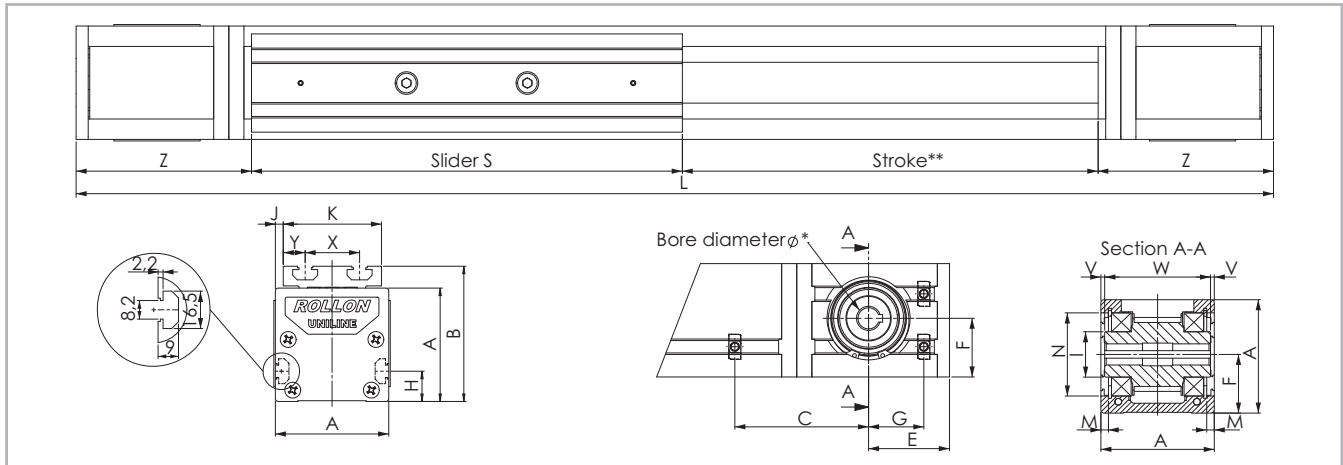

\* For information on the motor connection bores, see ordering key. \*\* The length of the safety stroke is provided on request according to the customer's specific requirements. Fig. 24

Type	A [mm]	B [mm]	C* [mm]	E [mm]	F [mm]	G* [mm]	H [mm]	I [mm]	J [mm]	K [mm]	M [mm]	N [mm]	S [mm]	X [mm]	Y [mm]	V [mm]	W [mm]	Z [mm]	Stroke** [mm]
C55	55	71	67.5	50.5	27.5	32.5	15	∅ 24.9	1.5	52	2.35	∅ 47	200	28	12	0.5	54	108	1850

\* For the position of the T-nuts when using our motor adapter plates, see pg. US-23ff  
 \*\* Maximum stroke for a single-piece guiding rail. For longer strokes, see tab. 38 Tab. 33

C55L with long slider

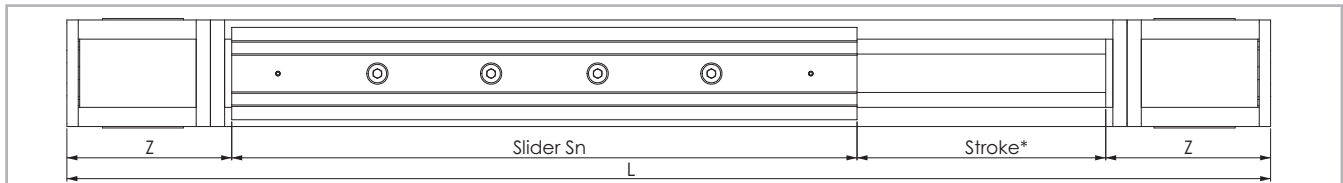

\* The length of the safety stroke is provided on request according to the customer's specific requirements. Fig. 25

Type	S <sub>min</sub> [mm]	S <sub>max</sub> [mm]	Sn [mm]	Z [mm]	Stroke* [mm]
C55L	310	500	$S_n = S_{min} + n \cdot 10$	108	1550

\* Maximum stroke for a single-piece guiding rail and a maximum slider plate length S<sub>max</sub>  
 For longer strokes, see tab. 38 Tab. 34

C55D with double slider

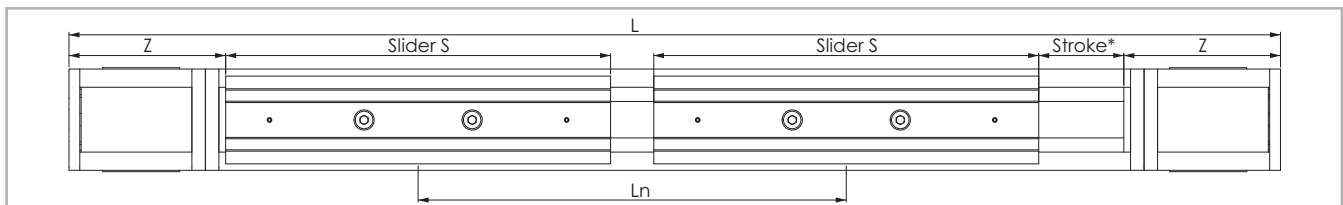

\* The length of the safety stroke is provided on request according to the customer's specific requirements. Fig. 26

Type	S [mm]	L <sub>min</sub> [mm]	L <sub>max</sub> ** [mm]	Ln [mm]	Z [mm]	Stroke* [mm]
C55D	200	300	1850	$L_n = L_{min} + n \cdot 5$	108	1570

\* Maximum stroke for a single-piece guiding rail and a minimum slider plate distance L<sub>min</sub>  
 \*\* Maximum distance L<sub>max</sub> between the centres of slider plates at a stroke of 0 mm  
 For longer strokes, see tab. 38 Tab. 35

## > Load ratings, moments and characteristic data

C55

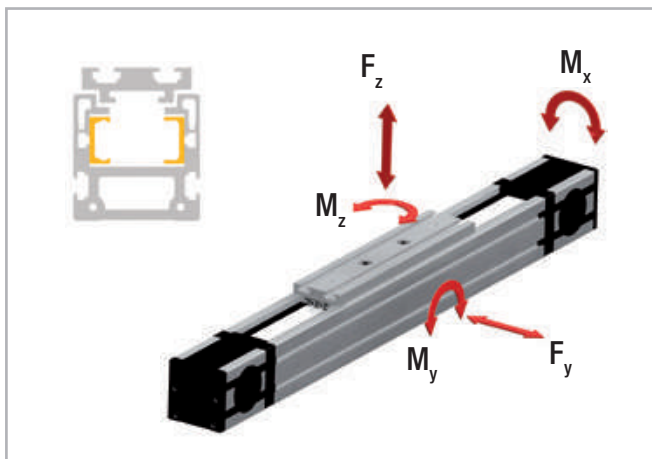

Fig. 27

### Driving belt

The driving belt is manufactured from a friction resistant polyurethane and with steel cords for high tensile stress resistance.

Type	Type of belt	Belt width [mm]	Weight [kg/m]
C55	18RPP5	18	0.074

Tab. 36

**Belt length (mm)** = 2 x L - 182 Standard slider

**Belt length (mm)** = 2 x L - S<sub>n</sub>+18 Long slider

**Belt length (mm)** = 2 x L - L<sub>n</sub> - 182 Double slider

Type	C [N]	F <sub>y</sub> [N]	F <sub>z</sub> [N]	M <sub>x</sub> [Nm]	M <sub>y</sub> [Nm]	M <sub>z</sub> [Nm]
C55	560	300	1640	18.5	65.6	11.7
C55-L	1120	600	3280	37	213 to 525	39 to 96
C55-D	1120	600	3280	37	492 to 3034	90 to 555

For the calculation of the allowed moments, please observe pages SL-5ff

Tab. 37

Technical data	Type
	C55
Standard belt tension [N]	220
Moment at no load [Nm]	0.3
Max. traversing speed [m/s]	3
Max. acceleration [m/s <sup>2</sup> ]	10
Repeat accuracy [mm]	0.1
Compact Rail guiding rail	TLV18 / ULV18
Slider type	2 CS18 spec.
Moment of inertia I <sub>y</sub> [cm <sup>4</sup> ]	34.4
Moment of inertia I <sub>z</sub> [cm <sup>4</sup> ]	45.5
Pitch diameter of pulley [m]	0.04138
Moment of inertia of each pulley [gmm <sup>2</sup> ]	45633
Stroke per shaft revolution [mm]	130
Mass of slider [g]	549
Weight with zero stroke [g]	2971
Weight with 1 m stroke [g]	4605
Max. stroke [mm]	5500
Working temperature	from -20 °C to + 80 °C

Tab. 38

> C75

C75 system

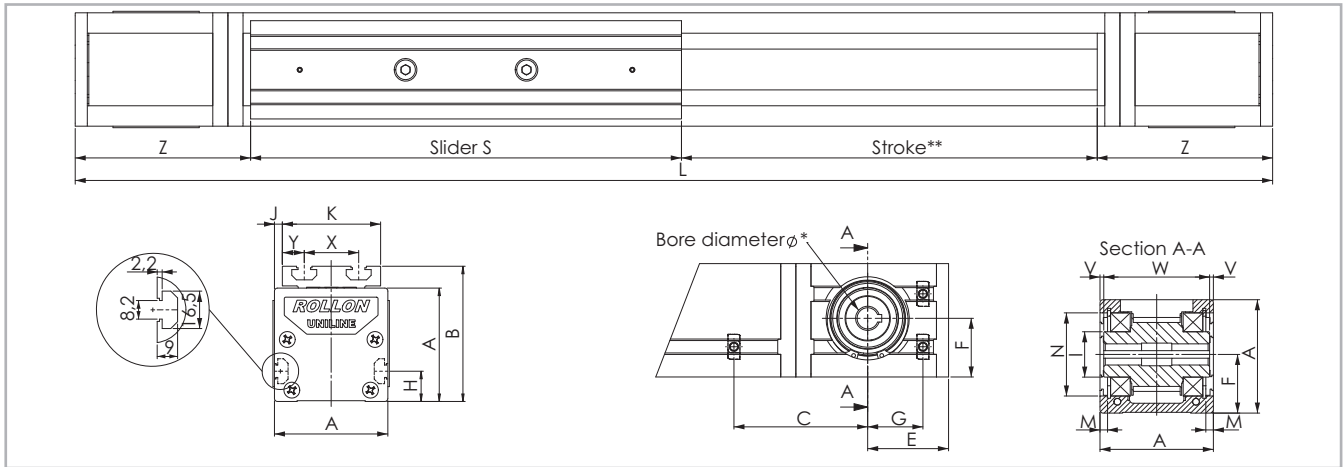

\* For information on the motor connection bores, see ordering key. \*\* The length of the safety stroke is provided on request according to the customer's specific requirements. Fig. 28

Type	A [mm]	B [mm]	C* [mm]	E [mm]	F [mm]	G* [mm]	H [mm]	I [mm]	J [mm]	K [mm]	M [mm]	N [mm]	S [mm]	X [mm]	Y [mm]	V [mm]	W [mm]	Z [mm]	Stroke** [mm]
C75	75	90	71.5	53.5	38.8	34.5	20	∅ 29.5	5	65	4.85	∅ 55	285	36	14.5	2.3	70.4	116	3000

\* For the position of the T-nuts when using our motor adapter plates, see pg. US-23ff Tab. 39  
 \*\* Maximum stroke for a single-piece guiding rail. For longer strokes, see tab. 44

C75L with long slider

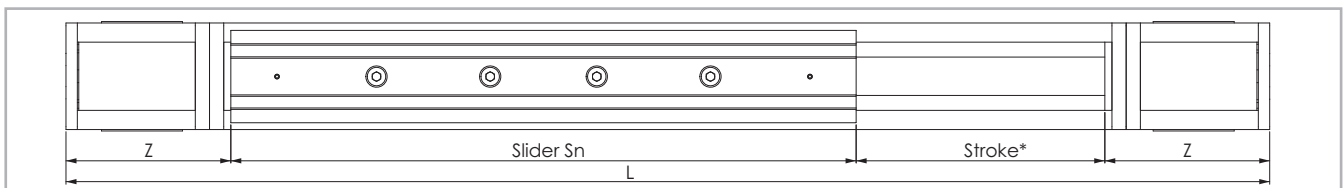

\* The length of the safety stroke is provided on request according to the customer's specific requirements. Fig. 30

Type	S <sub>min</sub> [mm]	S <sub>max</sub> [mm]	Sn [mm]	Z [mm]	Stroke* [mm]
C75L	440	700	$S_n = S_{min} + n \cdot 10$	116	2610

\* Maximum stroke for a single-piece guiding rail and a maximum slider plate length S<sub>max</sub>. For longer strokes, see tab. 44 Tab. 40

C75D with double slider

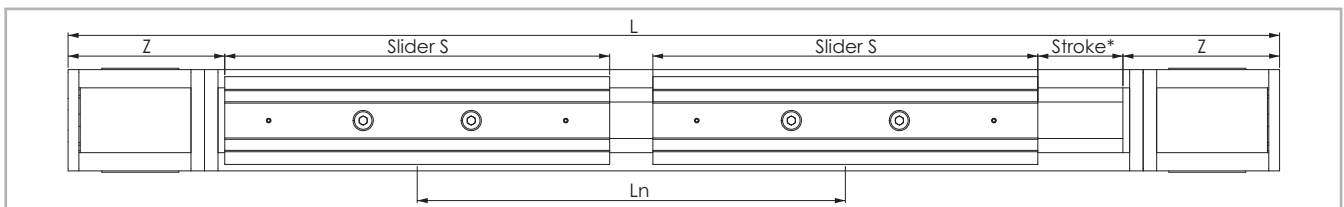

\* The length of the safety stroke is provided on request according to the customer's specific requirements. Fig. 30

Type	S [mm]	L <sub>min</sub> [mm]	L <sub>max</sub> ** [mm]	Ln [mm]	Z [mm]	Stroke* [mm]
C75D	285	416	3024	$L_n = L_{min} + n \cdot 8$	116	2610

\* Maximum stroke for a single-piece guiding rail and a minimum slider plate distance L<sub>min</sub> Tab. 41  
 \*\* Maximum distance L<sub>max</sub> between the centres of slider plates at a stroke of 0 mm. For longer strokes, see tab. 44

## > Load ratings, moments and characteristic data

C75

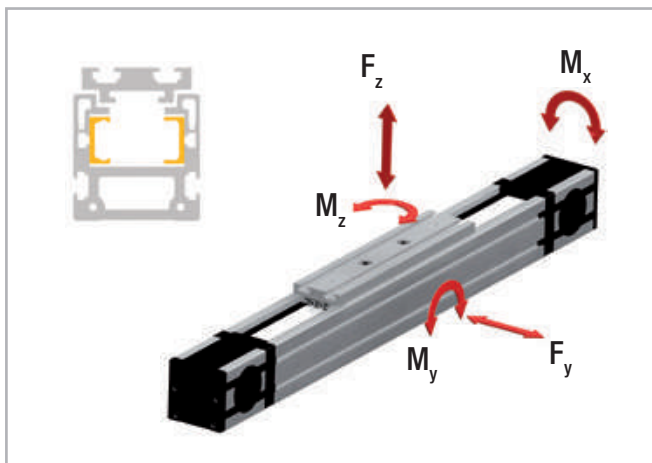

Fig. 31

### Driving belt

The driving belt is manufactured from a friction resistant polyurethane and with steel cords for high tensile stress resistance.

Type	Type of belt	Belt width [mm]	Weight [kg/m]
C75	30RPP8	30	0.185

Tab. 42

**Belt length (mm)** = 2 x L - 213 Standard slider

**Belt length (mm)** = 2 x L - S<sub>n</sub>+72 Long slider

**Belt length (mm)** = 2 x L - L<sub>n</sub> - 213 Double slider

Type	C [N]	F <sub>y</sub> [N]	F <sub>z</sub> [N]	M <sub>x</sub> [Nm]	M <sub>y</sub> [Nm]	M <sub>z</sub> [Nm]
C75	1470	750	4350	85.2	217	36.1
C75-L	2940	1500	8700	170.4	674 to 1805	116 to 311
C75-D	2940	1500	8700	170.4	1809 to 13154	312 to 2268

For the calculation of the allowed moments, please observe pages SL-5ff

Tab. 43

Technical data	Type
	C75
Standard belt tension [N]	800
Moment at no load [Nm]	1.3
Max. traversing speed [m/s]	5
Max. acceleration [m/s <sup>2</sup> ]	15
Repeat accuracy [mm]	0.1
Compact Rail guiding rail	TLV28 / ULV28
Slider type	2 CS28 spec.
Moment of inertia I <sub>y</sub> [cm <sup>4</sup> ]	108
Moment of inertia I <sub>z</sub> [cm <sup>4</sup> ]	155
Pitch diameter of pulley [m]	0.05093
Moment of inertia of each pulley [gmm <sup>2</sup> ]	139969
Stroke per shaft revolution [mm]	160
Mass of slider [g]	1666
Weight with zero stroke [g]	6853
Weight with 1 m stroke [g]	9151
Max. stroke [mm]	7500
Working temperature	from -20 °C to + 80 °C

Tab. 44

## > Lubrication

The raceways of the guide rails in the Uniline linear axes are prelubricated. To achieve the calculated service life, a lubrication film must always be present between the raceway and the roller. The lubrication film also provides anticorrosion protection to the ground raceways. An approximate value for the lubrication period is every 100 km or every six months. The recommended lubricant is a lithium-based roller bearing grease of medium consistency.

### Lubrication of the raceways

Proper lubrication under normal conditions:

- reduces friction
- reduces wear
- reduces stress on the contact faces
- reduces running noise

Lubricants	Thickeners	Temperature range [°C]	Dynamic viscosity [mPas]
Roller bearing grease	Lithium soap	-30 to +170	<4500

Tab. 45

### Relubrication of the guide rails

1. Slide the slider plate to one end of the unit.
2. At about half the stroke press and manually move the belt in order to see one of the two rails inside the unit (see Fig. 32).  
It may be necessary to release or loosen the belt tension. See chapter Belt tension (pg. US-59).
3. By using a grease syringe (not supplied by ROLLON) or an alternative tool (i.e. brush), apply a sufficient quantity of grease on the raceways.
4. If required, re-establish the recommended belt tension (see pg. US-59).
5. Finally slide the slider plate back and forth over the entire stroke, in order to distribute the grease over the entire length of the rail.

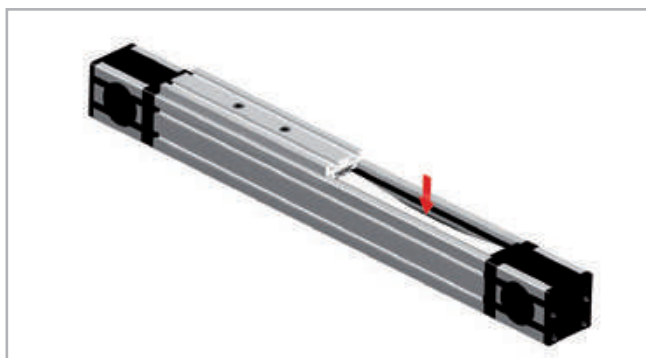

Fig. 32

### Cleaning the guide rails

It is always recommended to clean the slider rail prior to any relubrication, in order to remove grease residues. This can be done while performing maintenance work or during a scheduled machine stop.

1. Unscrew the safety screws C (on top of the slider plate) from the belt tensioning device A (see fig. 33).
2. Also completely unscrew the belt tensioning screws B and remove the belt tensioning devices A from their housings.
3. Lift the toothed belt until the guide rails can be seen.  
Important: Ensure that the side seal is not damaged.
4. Clean the rail raceways with a clean and dry cloth. Ensure that all grease and dirt residues from previous work processes are removed.  
To ensure that the rails are cleaned over their entire length, the slider plate should be moved once over its entire length.
5. Apply a sufficient amount of grease to the raceways.

6. Re-insert the belt tensioning devices A into their housings and mount the belt tensioning screws B. Re-adjust the belt tension (see pg. US-59).
7. Fasten the safety screws C.

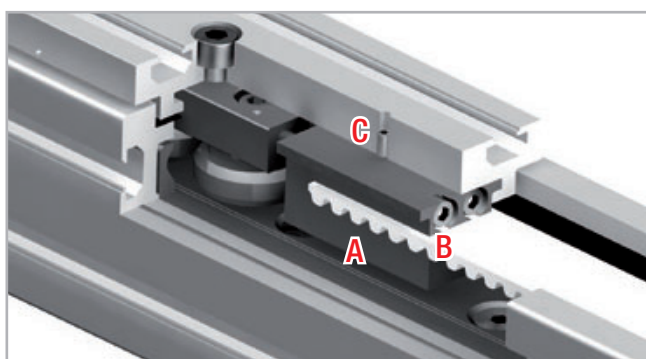

Fig. 33

## > Accessories

### Adapter plates

#### Standard motor adapter plates AC2

Mounting plates for the most common motors or gearboxes. The connection bores for the motors or gearboxes must be made on site. All plates are delivered with M6 x 10 screws to DIN 912 and T-nuts for mounting on the linear units.

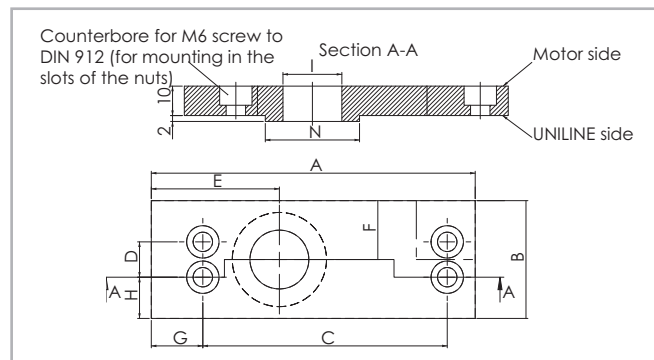

Fig. 34

Size	A [mm]	B [mm]	C [mm]	D [mm]	E [mm]	F [mm]	G [mm]	H [mm]	I [mm]	N [mm]
55	126	55	100	25	50.5	27.5	18	15	Ø 30	Ø 47
75	135	70	106	35	53.5	35	19	17.5	Ø 35	Ø 55

Tab. 46

#### NEMA plates AC1-P

Mounting plates for NEMA motors or gearboxes. These plates are delivered ready-to-mount on the linear axes. All plates are delivered with M6 x 10 screws to DIN 912 and T-nuts for mounting on the linear units.

Size	NEMA Motors / Gearboxes
55	NEMA 34
75	NEMA 42

Tab. 47

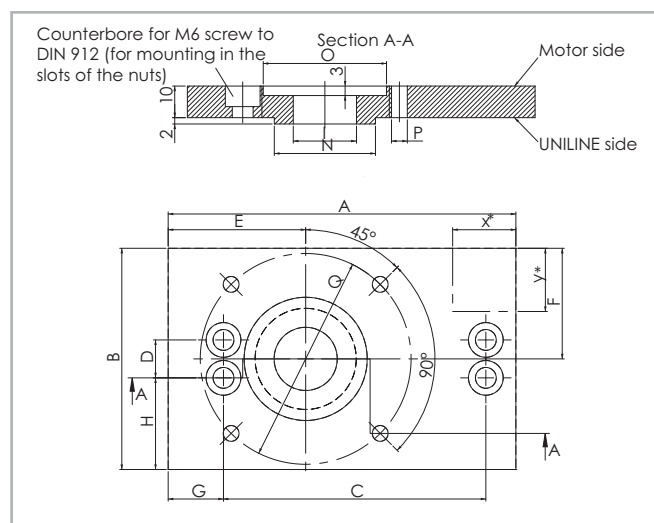

Fig. 35

Size	A [mm]	B [mm]	C [mm]	D [mm]	E [mm]	F [mm]	G [mm]	H [mm]	I [mm]	N [mm]	O [mm]	P [mm]	Q [mm]
55	126	100	100	25	50.5	50	18	37.5	30	Ø 47	Ø 74	Ø 5.5	Ø 98.4
75	135	120	106	35	53.5	60	19	42.5	35	Ø 55	Ø 57	Ø 7.1	Ø 125.7

Tab. 48

#### Synchronous use of linear axes in pairs

If two axes are to be used in parallel using a connecting shaft, please specify when ordering, to ensure that the key slots of the pulleys are synchronized.

**Fixing brackets APF-2**

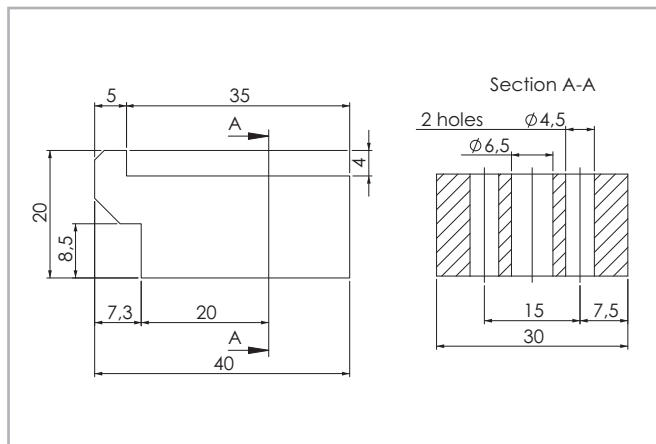

Fig. 36

Fixing clamp for simple mounting of a linear axis on a mounting surface or for connecting two units with or without a connection plate (see pg. US-63).

A spacer\* may be necessary.

\*(Any spacer that may be necessary must be manufactured on site)

**T-nut**

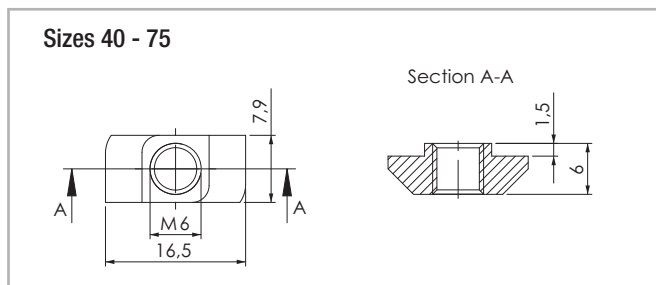

Fig. 37

The maximum tightening torque is 10 Nm.

**Assembly kits**

**T-connection plate APC-1**

T-connection plate allows two units to be mounted perpendicular to each other (see pg. US-60). The plate will not interfere with the strokes of either unit. All plates are delivered with M6 x 10 screws to DIN 912 and T-nuts for mounting on the linear units.

**Note**

In case of use of APC-1 plates with E and ED series, please consult Rollon Technical Dpt. In standard there is an interference between U-rail and APC-1 plate. A special version with shorter U-rail at both extremities will be offered.

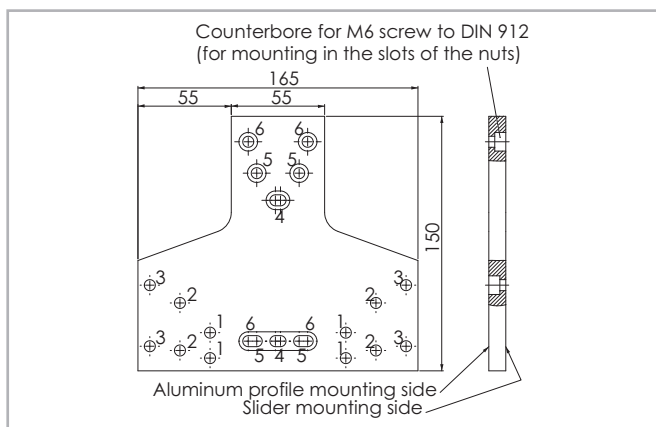

Fig. 38

Size	Fixing holes for the slider	Fixing holes for the profile
55	Holes 2	Holes 5
75	Holes 3	Holes 6

Tab. 49



**Angle connection plate APC-2**

allows the right angle mounting of two units. The trolley of one unit can be mounted to the side of the other (see pg. US-61). The plate will not interfere with the strokes of either unit. All plates are delivered with M6 x 10 screws to DIN 912 and T-nuts for mounting to the linear units.

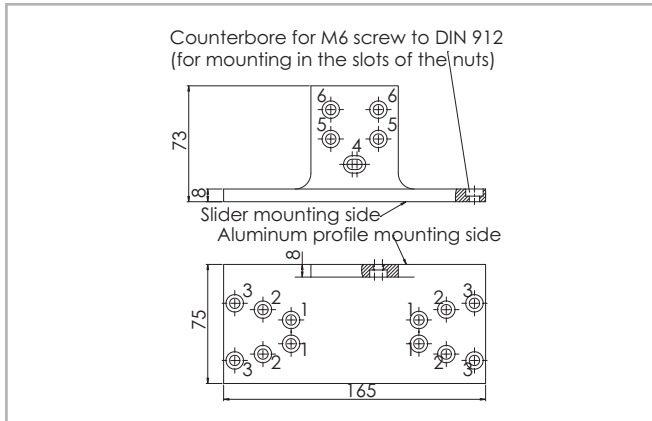

Fig. 39

Size	Fixing holes for the slider	Fixing holes for the profile
55	Holes 2	Holes 5
75	Holes 3	Holes 6

Tab. 50

**X connection plate APC-3**

X connection plate for mounting two sliders perpendicular to each other (see pg. US-62). The plate will not interfere with the strokes of either unit. All plates are delivered with M6 x 10 screws to DIN 912 and T-nuts for mounting on the linear units.

Size	Fixing holes for slider 1	Fixing holes for slider 2
55	Holes 2	Holes 5
75	Holes 3	Holes 6

Tab. 51

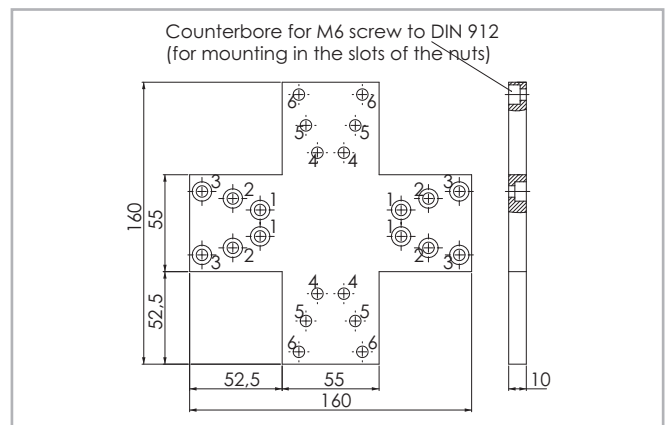

Fig. 40

**Ordering key** 

**> Identification code for Uniline linear unit**

U	C	07 05=55 07=75	1A	1190	1A	D 500	L 350	
						Indices of long slider plate <i>see from pg. US-18 to pg. US-20</i>		
						Indices of double slider plate, <i>distance of the centers of slider plates</i> <i>see from pg. US-18 to pg. US-20</i>		
						Profile/Rail code		
						L= Total length of the unit		
						Driving head code		
		Size				<i>see from pg. US-18 to pg. US-20</i>		
		Type						
Uniline prefix								

Ordering example: UC 07 1A 1190 1A D 500 L 350

In order to create identification codes for Actuator Line, you can visit: <http://configureactuator.rollon.com>



**Left / right orientation**

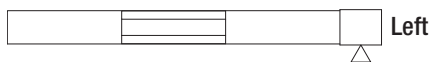

## > Accessories

### Standard motor adapter plate

<b>C</b>	<b>07</b>	<b>AC2</b>	
	<b>05=55</b>		
	<b>07=75</b>		
	Size	see pg. US-23	
Type			

Ordering example: C07-AC2

### NEMA motor adapter plates

<b>C</b>	<b>07</b>	<b>AC1</b>	
	<b>05=55</b>		
	<b>07=75</b>		
	Size	see pg. US-23	
Type			

Ordering example: C07-AC1

**T-connection plate**      Order code: APC-1, s. pg. US-24

**Angle connection plate**      Order code: APC-2, s. pg. US-25

**X connection plate**      Order code: APC-3, s. pg. US-26

**Fixing clamp**      Order code: APF-2, s. pg. US-24

### Motor connection bores

Hole [Ø]	Size		Head code
	55	75	
<b>Metric [mm]</b> with slot for key	12G8 / 4js9	14G8 / 5js9	1A
	10G8 / 3js9	16G8 / 5js9	2A
	14G8 / 5js9	19G8 / 6js9	3A
	16G8 / 5js9		4A
<b>Metric [mm]</b> for compression coupling		18	1B
		24	2B
<b>Inch [in]</b> with slot for key	1/2 / 1/8	5/8 / 3/16	1P
	3/8 / 1/8		2P
	5/8 / 3/16		3P

Tab. 52

The highlighted connection bores are standard connections

Metric: key seat for keys to DIN 6885 form A

Inch: key seat for keys to BS 46 Part 1: 1958

## Uniline E series



### > Uniline E series description



Fig. 41

Uniline is a family of ready-to-install linear actuators. They consist of internal Compact Rail roller sliders and steel-reinforced polyurethane belts in a rigid aluminum profile. Longitudinal seals enclose the system. This arrangement provides the best protection for the actuator from soiling and damage. In the E series, the fixed bearing rail (T-rail) is mounted horizontally in the aluminum profile, and the compensating bearing rail (U-rail) is flanged to the outside of the profile as moment support. Versions with long (L) or double (D) sliders in one axis are possible.

#### The most important characteristics:

- Compact design
- Protected internal linear guides
- High traversing speeds
- Grease-free operation possible (depending on the application. For further information, please contact our Application Engineering department)
- High versatility
- Long strokes
- Versions with long or multiple sliders available in one linear axis

#### Preferred areas of application:

- Handling and automation
- Multi-axis gantries
- Packaging machines
- Cutting machines
- Displaceable panels
- Painting installations
- Welding robots
- Special machines

#### Technical data:

- Available sizes [mm]:  
Type E: 55, 75
- Length and stroke tolerances:  
For strokes <1 m: +0 mm to +10 mm (+0 in to 0.4 in)  
For strokes >1 m: +0 mm to +15 mm (+0 in to 0.59 in)

## > The components

### Extruded profile

The anodized 6060 aluminum alloy extrusion used for the profile of the Rollon Uniline E series linear units were designed and manufactured by industry experts to optimize weight while maintaining mechanical strength. (see physical-chemical characteristics below). The dimensional tolerances comply with EN 755-9 standard.

### Driving belt

The Rollon Uniline E series linear units use steel reinforced polyurethane drive belts with RPP pitch and parabolic profiles. This belt is ideal due to its high load transmission characteristics, compact size and low noise. Used in conjunction with a backlash-free pulley, smooth alternating motion can

be achieved. Optimization of the maximum belt width/body dimension ratio enables the following performance characteristics to be achieved:

- High speed
- Low noise
- Low wear

### Carriage

The carriage of the Rollon Uniline E series linear units are made entirely of anodized aluminum. Each carriage has mounting T-slots for the connection to the moving element. Rollon offers multiple carriages to accommodate a vast array of applications.

### General data about aluminum used: AL 6060

Chemical composition [%]

Al	Mg	Si	Fe	Mn	Zn	Cu	Impurites
Remaining	0.35-0.60	0.30-0.60	0.30	0.10	0.10	0.10	0.05-0.15

Tab. 53

Physical characteristics

Density	Coeff. of elasticity	Coeff. of thermal expansion (20°-100°C)	Thermal conductivity (20°C)	Specific heat (0°-100°C)	Resistivity	Melting point
$\frac{\text{kg}}{\text{dm}^3}$	$\frac{\text{kN}}{\text{mm}^2}$	$\frac{10^{-6}}{\text{K}}$	$\frac{\text{W}}{\text{m} \cdot \text{K}}$	$\frac{\text{J}}{\text{kg} \cdot \text{K}}$	$\Omega \cdot \text{m} \cdot 10^{-9}$	°C
2.7	69	23	200	880-900	33	600-655

Tab. 54

Mechanical characteristics

Rm	Rp (02)	A	HB
$\frac{\text{N}}{\text{mm}^2}$	$\frac{\text{N}}{\text{mm}^2}$	%	—
205	165	10	60-80

Tab. 55

> E55

E55 system

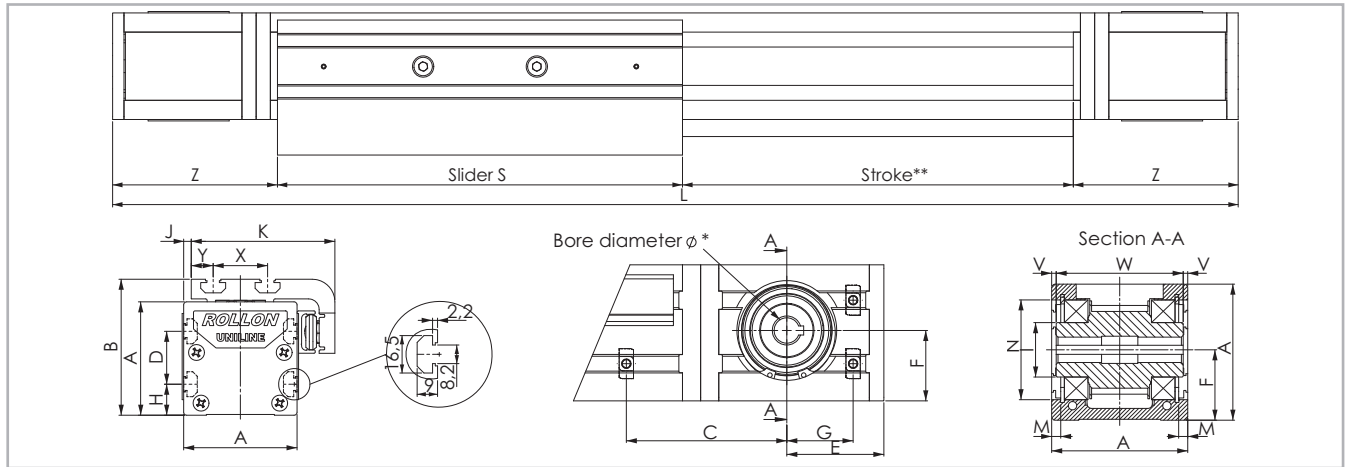

\* For information on the motor connection bores, see ordering key. \*\* The length of the safety stroke is provided on request according to the customer's specific requirements. Fig. 42

Type	A [mm]	B [mm]	C* [mm]	D [mm]	E [mm]	F [mm]	G* [mm]	H [mm]	I [mm]	J [mm]	K [mm]	M [mm]	N [mm]	S [mm]	X [mm]	Y [mm]	V [mm]	W [mm]	Z [mm]	Stroke** [mm]
E55	55	71	67.5	25	50.5	27.5	32.5	15	∅ 24.9	1.5	71	2.35	∅ 47	200	28	12	0.5	54	108	3070

\* For the position of the T-nuts when using our motor adapter plates, see pg. US-35ff Tab. 56  
 \*\* Maximum stroke for a single-piece guiding rail. For longer strokes, see tab. 61

E55L with long slider

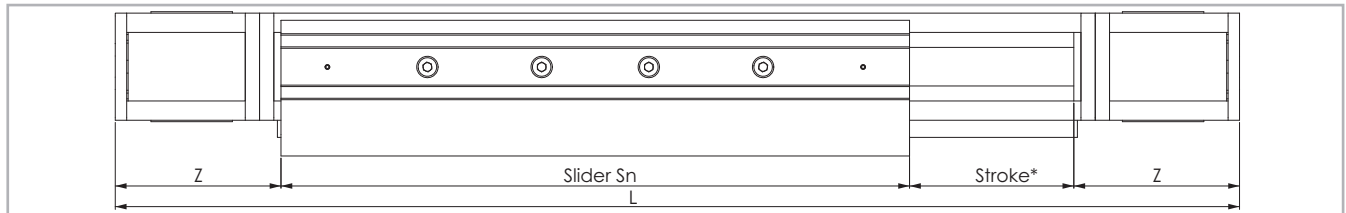

\* The length of the safety stroke is provided on request according to the customer's specific requirements. Fig. 43

Type	S <sub>min</sub> [mm]	S <sub>max</sub> [mm]	Sn [mm]	Z [mm]	Stroke* [mm]
E55L	310	500	$S_n = S_{min} + n \cdot 10$	108	2770

\* Maximum stroke for a single-piece guiding rail and a maximum slider plate length S<sub>max</sub> Tab. 57  
 For longer strokes, see tab. 61

E55D with double slider

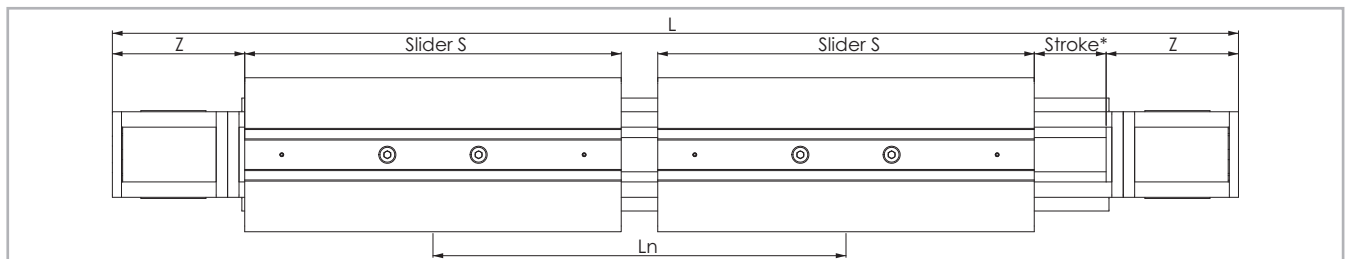

\* The length of the safety stroke is provided on request according to the customer's specific requirements. Fig. 44

Type	S [mm]	L <sub>min</sub> [mm]	L <sub>max</sub> ** [mm]	Ln [mm]	Z [mm]	Stroke* [mm]
E55D	200	300	3070	$L_n = L_{min} + n \cdot 5$	108	2770

\* Maximum stroke for a single-piece guiding rail and a minimum slider plate distance L<sub>min</sub> Tab. 58  
 \*\* Maximum distance L<sub>max</sub> between the centres of slider plates at a stroke of 0 mm  
 For longer strokes, see tab. 61

> Load ratings, moments and characteristic data

E55

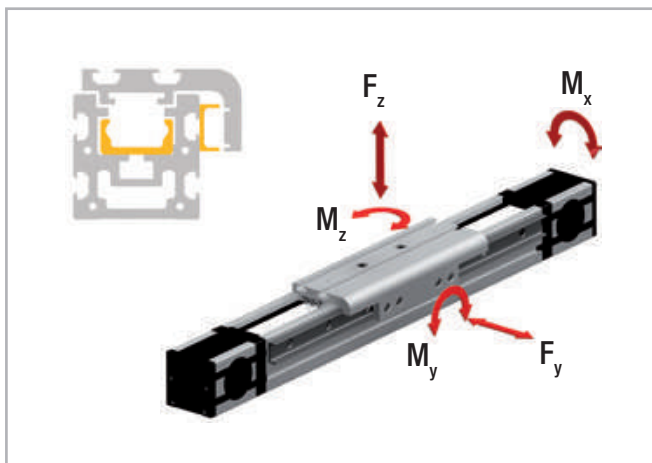

Fig. 45

**Driving belt**

The driving belt is manufactured from a friction resistant polyurethane and with steel cords for high tensile stress resistance.

Type	Type of belt	Belt width [mm]	Weight [kg/m]
E55	18RPP5	18	0.074

Tab. 59

**Belt length (mm)** = 2 x L - 182 Standard slider

**Belt length (mm)** = 2 x L - S<sub>n</sub>+18 Long slider

**Belt length (mm)** = 2 x L - L<sub>n</sub> - 182 Double slider

Type	C [N]	F <sub>y</sub> [N]	F <sub>z</sub> [N]	M <sub>x</sub> [Nm]	M <sub>y</sub> [Nm]	M <sub>z</sub> [Nm]
E55	4260	2175	1500	25.5	43.4	54.4
E55-L	8520	4350	3000	51	165 to 450	239 to 652
E55-D	8520	4350	3000	51	450 to 4605	652 to 6677

For the calculation of the allowed moments, please observe pages SL-5ff

Tab. 60

Technical data	Type
	E55
Standard belt tension [N]	220
Moment at no load [Nm]	0.3
Max. traversing speed [m/s]	3
Max. acceleration [m/s <sup>2</sup> ]	10
Repeat accuracy [mm]	0.1
Compact Rail guiding rail	TLV28 / ULV18
Slider type	CS28 spec. / CPA 18
Moment of inertia I <sub>y</sub> [cm <sup>4</sup> ]	34.6
Moment of inertia I <sub>z</sub> [cm <sup>4</sup> ]	41.7
Pitch diameter of pulley [m]	0.04138
Moment of inertia of each pulley [gmm <sup>2</sup> ]	45633
Stroke per shaft revolution [mm]	130
Mass of slider [g]	635
Weight with zero stroke [g]	3167
Weight with 1 m stroke [g]	5055
Max. stroke [mm]	5500
Working temperature	from -20 °C to + 80 °C

Tab. 61

> E75

E75 system

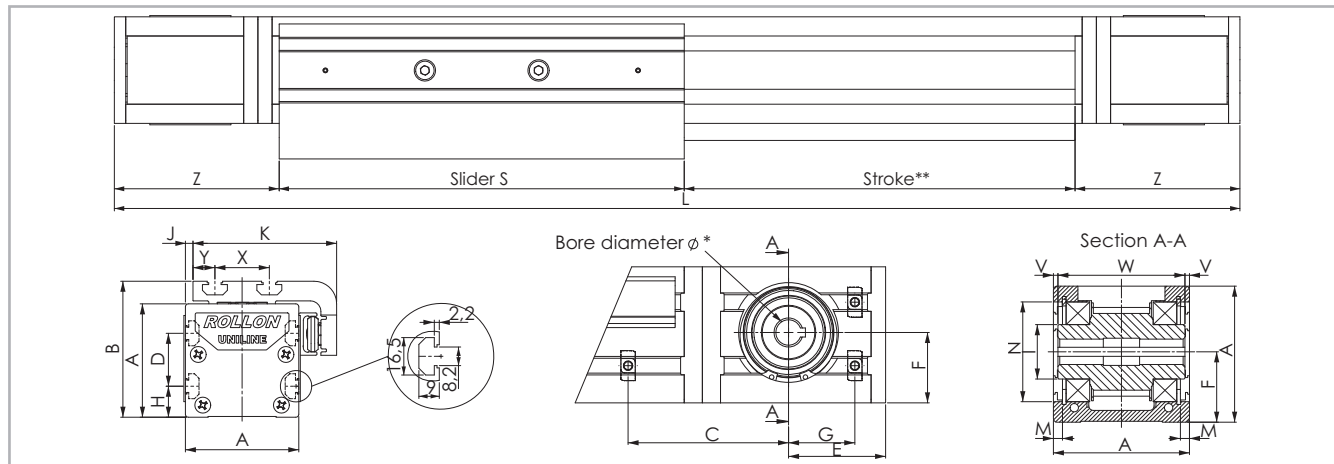

\* For information on the motor connection bores, see ordering key. \*\* The length of the safety stroke is provided on request according to the customer's specific requirements. Fig. 46

Type	A [mm]	B [mm]	C* [mm]	D [mm]	E [mm]	F [mm]	G* [mm]	H [mm]	I [mm]	J [mm]	K [mm]	M [mm]	N [mm]	S [mm]	X [mm]	Y [mm]	V [mm]	W [mm]	Z [mm]	Stroke** [mm]
E75	75	90	71.5	35	53.5	38.8	34.5	20	∅ 29.5	5	95	4.85	∅ 55	285	36	14.5	2.3	70.4	116	3420

\* For the position of the T-nuts when using our motor adapter plates, see pg. US-35ff Tab. 62

\*\* Maximum stroke for a single-piece guiding rail. For longer strokes, see tab. 67

E75L with long slider

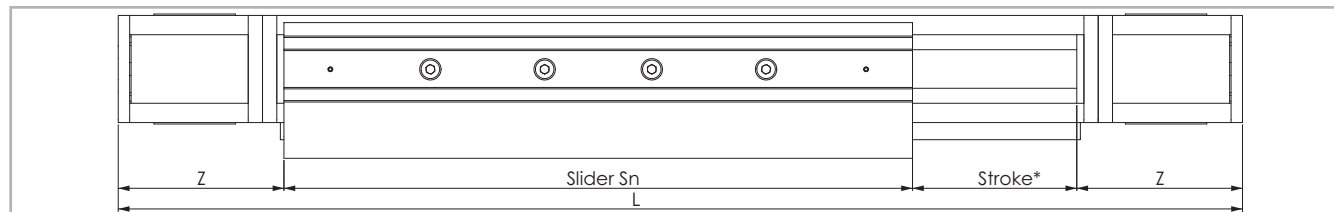

\* The length of the safety stroke is provided on request according to the customer's specific requirements. Fig. 47

Type	S <sub>min</sub> [mm]	S <sub>max</sub> [mm]	Sn [mm]	Z [mm]	Stroke* [mm]
E75L	440	700	$S_n = S_{min} + n \cdot 10$	116	3000

\* Maximum stroke for a single-piece guiding rail and a maximum slider plate length S<sub>max</sub> For longer strokes, see tab. 67 Tab. 63

E75D with double slider

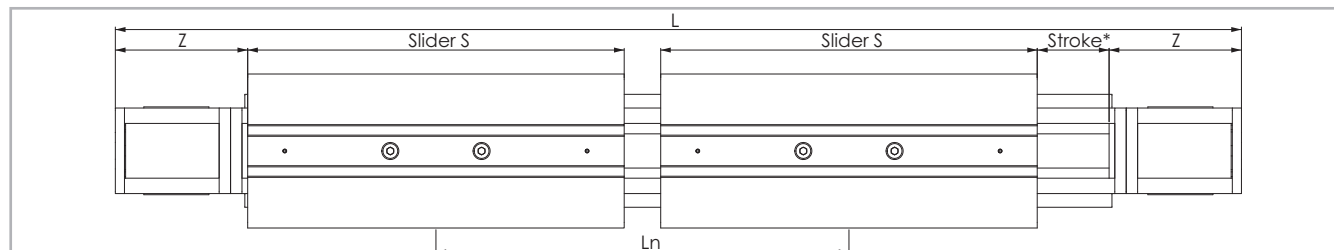

\* The length of the safety stroke is provided on request according to the customer's specific requirements. Fig. 48

Type	S [mm]	L <sub>min</sub> [mm]	L <sub>max</sub> ** [mm]	Ln [mm]	Z [mm]	Stroke* [mm]
E75D	285	416	3416	$L_n = L_{min} + n \cdot 8$	116	3000

\* Maximum stroke for a single-piece guiding rail and a minimum slider plate distance L<sub>min</sub> \*\* Maximum distance L<sub>max</sub> between the centres of slider plates at a stroke of 0 mm For longer strokes, see tab. 67 Tab. 64



> Load ratings, moments and characteristic data

E75

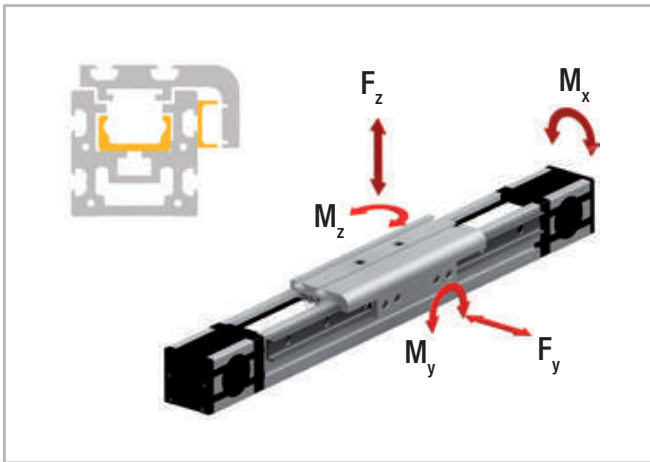

Fig. 49

Driving belt

The driving belt is manufactured from a friction resistant polyurethane and with steel cords for high tensile stress resistance.

Type	Type of belt	Belt width [mm]	Weight [kg/m]
E75	30RPP8	30	0.185

Tab. 65

Belt length (mm) = 2 x L - 213 Standard slider

Belt length (mm) = 2 x L - S<sub>n</sub>+72 Long slider

Belt length (mm) = 2 x L - L<sub>n</sub> - 213 Double slider

Type	C [N]	F <sub>y</sub> [N]	F <sub>z</sub> [N]	M <sub>x</sub> [Nm]	M <sub>y</sub> [Nm]	M <sub>z</sub> [Nm]
E75	12280	5500	3710	85.5	163	209
E75-L	24560	11000	7420	171	575 to 1540	852 to 2282
E75-D	24560	11000	7420	171	1543 to 12673	2288 to 18788

For the calculation of the allowed moments, please see pages SL-5ff

Tab. 66

Technical data	Type
	E75
Standard belt tension [N]	800
Moment at no load [Nm]	1.3
Max. traversing speed [m/s]	5
Max. acceleration [m/s <sup>2</sup> ]	15
Repeat accuracy [mm]	0.1
Compact Rail guiding rail	TLV43 / ULV28
Slider type	CS43 spec. / CPA 28
Moment of inertia I <sub>y</sub> [cm <sup>4</sup> ]	127
Moment of inertia I <sub>z</sub> [cm <sup>4</sup> ]	172
Pitch diameter of pulley [m]	0.05093
Moment of inertia of each pulley [gmm <sup>2</sup> ]	139969
Stroke per shaft revolution [mm]	160
Mass of slider [g]	1772
Weight with zero stroke [g]	7544
Weight with 1 m stroke [g]	10751
Max. stroke [mm]	7500
Working temperature	from -20 °C to + 80 °C

Tab. 67

## > Lubrication

The raceways of the guide rails in the Uniline linear axes are prelubricated. To achieve the calculated service life, a lubrication film must always be present between the raceway and the roller. The lubrication film also provides anticorrosion protection to the ground raceways. An approximate value for the lubrication period is every 100 km or every six months. The recommended lubricant is a lithium-based roller bearing grease of medium consistency.

### Lubrication of the raceways

Proper lubrication under normal conditions:

- reduces friction
- reduces wear
- reduces stress on the contact faces
- reduces running noise

Lubricants	Thickeners	Temperature range [°C]	Dynamic viscosity [mPas]
Roller bearing grease	Lithium soap	-30 to +170	<4500

Tab. 68

### Relubrication of the guide rails

These types of rails have a lubricating conduit on the side of the slider plate through which the lubricant can be applied directly to the raceways. Lubrication can be done in one of two ways:

#### 1. Relubrication using a grease gun:

This is done by inserting the tip of the grease gun into the conduit at the slider plate and injecting the grease inside (see fig. 50). Please note that the grease has to fill the whole conduit in order to lubricate the rail properly; for this reason sufficient grease must be used.

#### 2. Automatic lubrication system:

To connect the unit to an automatic greasing system, use a proper adapter/connector\* that attaches to the threaded hole on the side of the trolley.

The advantage of this solution is the possibility of rail re-lubrication without machine downtime.

\*(Any adapter that may be necessary must be manufactured on site)

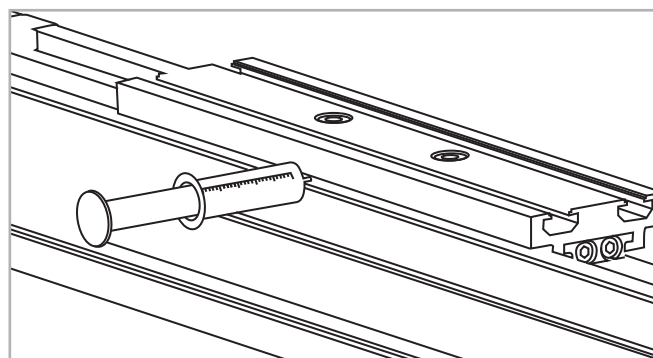

Fig. 50

### Cleaning the guide rails

It is always recommended to clean the slider rail prior to any relubrication, in order to remove grease residues. This can be done while performing maintenance work or during a scheduled machine stop.

1. Unscrew the safety screws C (on top of the slider plate) from the belt tensioning device A (see fig. 51).
2. Also completely unscrew the belt tensioning screws B and remove the belt tensioning devices A from their housings.
3. Lift the toothed belt until the guide rails can be seen.  
Important: Ensure that the side seal is not damaged.
4. Clean the rail raceways with a clean and dry cloth. Ensure that all grease and dirt residues from previous work processes are removed.  
To ensure that the rails are cleaned over their entire length, the slider plate should be moved once over its entire length.
5. Apply a sufficient amount of grease to the raceways.

6. Re-insert the belt tensioning devices A into their housings and mount the belt tensioning screws B. Re-adjust the belt tension (see pg. US-59).
7. Fasten the safety screws C.

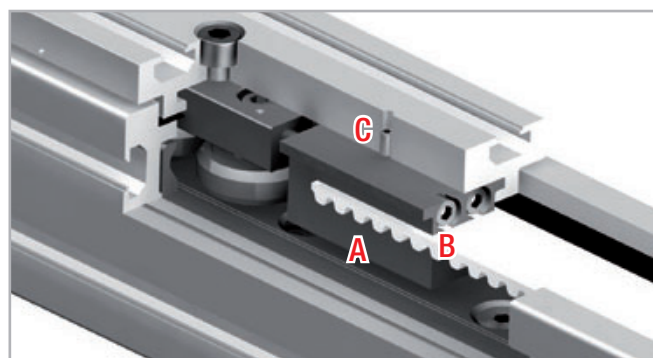

Fig. 51

## > Accessories

### Adapter plates

#### Standard motor adapter plates AC2

Mounting plates for the most common motors or gearboxes. The connection bores for the motors or gearboxes must be made on site. All plates are delivered with M6 x 10 screws to DIN 912 and T-nuts for mounting on the linear units.

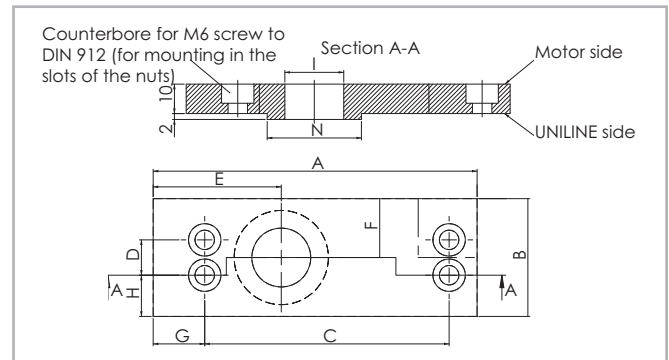

Fig. 52

Size	A [mm]	B [mm]	C [mm]	D [mm]	E [mm]	F [mm]	G [mm]	H [mm]	I [mm]	N [mm]
55	126	55	100	25	50.5	27.5	18	15	Ø 30	Ø 47
75	135	70	106	35	53.5	35	19	17.5	Ø 35	Ø 55

Tab. 69

#### NEMA plates AC1-P

Mounting plates for NEMA motors or gearboxes. These plates are delivered ready-to-mount on the linear axes. All plates are delivered with M6 x 10 screws to DIN 912 and T-nuts for mounting on the linear units.

Size	NEMA Motors / Gearboxes
55	NEMA 34
75	NEMA 42

Tab. 70

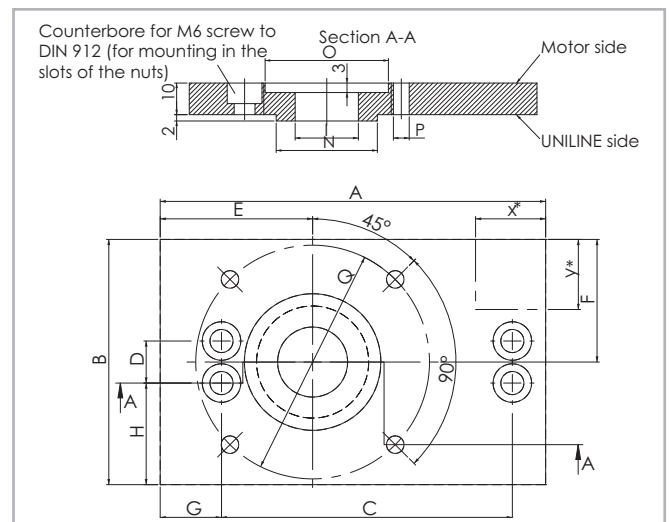

Fig. 53

Size	A [mm]	B [mm]	C [mm]	D [mm]	E [mm]	F [mm]	G [mm]	H [mm]	I [mm]	N [mm]	O [mm]	P [mm]	Q [mm]
55	126	100	100	25	50.5	50	18	37.5	30	Ø 47	Ø 74	Ø 5.5	Ø 98.4
75	135	120	106	35	53.5	60	19	42.5	35	Ø 55	Ø 57	Ø 7.1	Ø 125.7

Tab. 71

#### Synchronous use of linear axes in pairs

If two axes are to be used in parallel using a connecting shaft, please specify when ordering, to ensure that the key slots of the pulleys are synchronized.

**Fixing brackets APF-2**

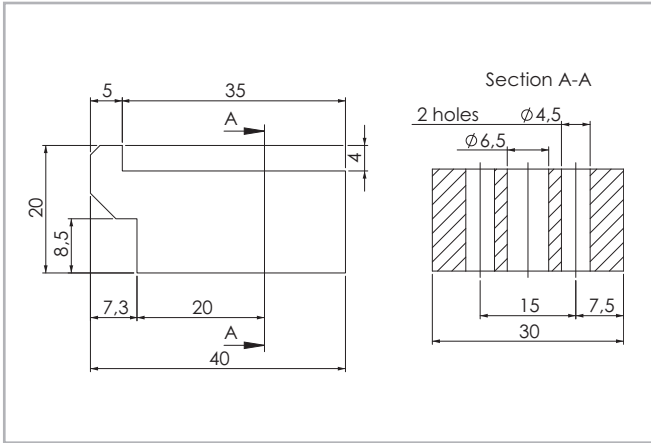

Fig. 54

Fixing clamp for simple mounting of a linear axis on a mounting surface or for connecting two units with or without a connection plate (see pg. US-63).

A spacer\* may be necessary.

\*(Any spacer that may be necessary must be manufactured on site)

**T-nut**

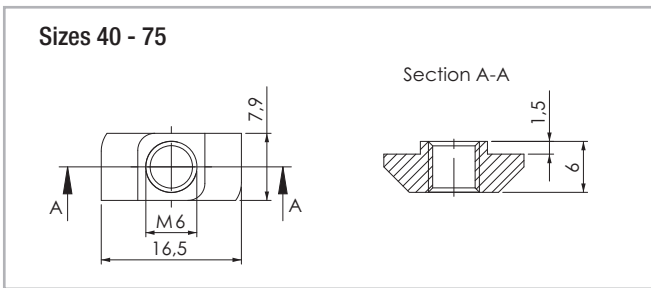

Fig. 55

The maximum tightening torque is 10 Nm.

**Assembly kits**

**T-connection plate APC-1**

T-connection plate allows two units to be mounted perpendicular to each other (see pg. US-60). The plate will not interfere with the strokes of either unit. All plates are delivered with M6 x 10 screws to DIN 912 and T-nuts for mounting on the linear units.

**Note**

In case of use of APC-1 plates with E and ED series, please consult Rollon Technical Dpt. In standard there is an interference between U-rail and APC-1 plate. A special version with shorter U-rail at both extremities will be offered.

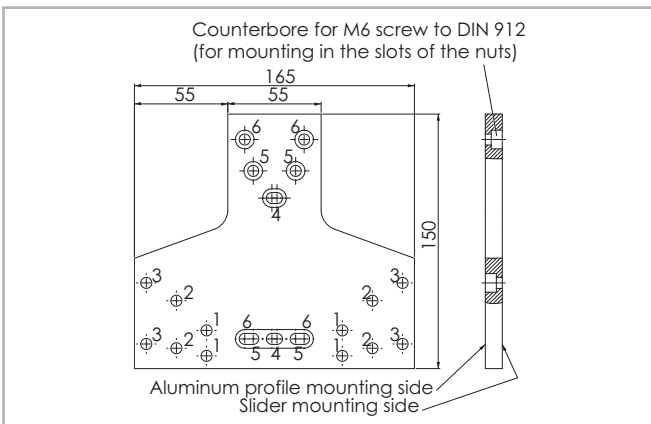

Fig. 56

Size	Fixing holes for the slider	Fixing holes for the profile
55	Holes 2	Holes 5
75	Holes 3	Holes 6

Tab. 72

**Angle connection plate APC-2**

allows the right angle mounting of two units. The trolley of one unit can be mounted to the side of the other (see pg. US-61). The plate will not interfere with the strokes of either unit. All plates are delivered with M6 x 10 screws to DIN 912 and T-nuts for mounting to the linear units.

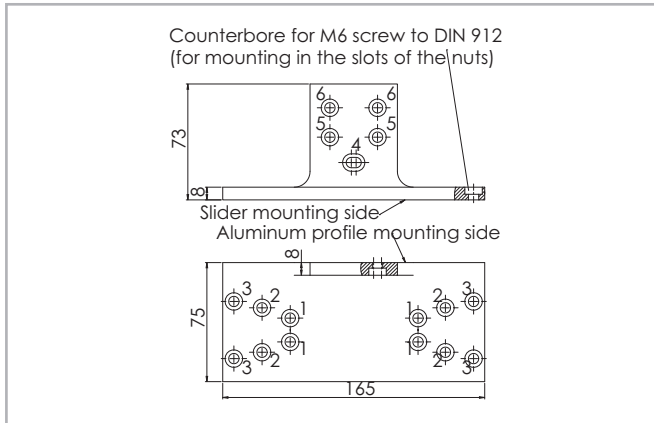

Fig. 57

**Note**

This adapter plate can be used with types E and ED only to a limited extent. For further information, please contact our Application Engineering Department.

Size	Fixing holes for the slider	Fixing holes for the profile
55	Holes 2	Holes 5
75	Holes 3	Holes 6

Tab. 73

**X connection plate APC-3**

X connection plate for mounting two sliders perpendicular to each other (see pg. US-62). The plate will not interfere with the strokes of either unit. All plates are delivered with M6 x 10 screws to DIN 912 and T-nuts for mounting on the linear units.

Size	Fixing holes for slider 1	Fixing holes for slider 2
55	Holes 2	Holes 5
75	Holes 3	Holes 6

Tab. 74

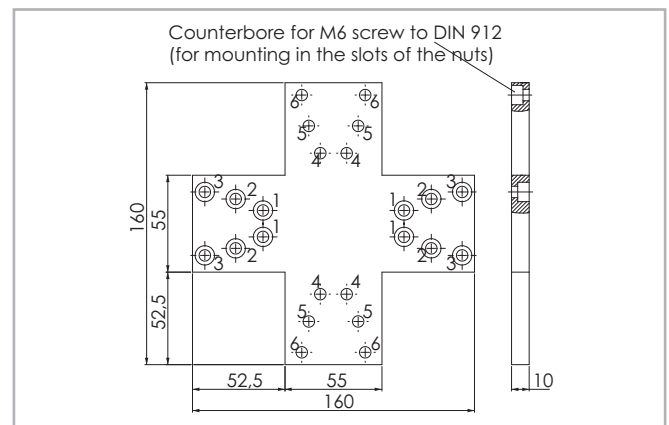

Fig. 58

**Ordering key** 

**> Identification code for Uniline linear unit**

U	E	07 05=55 07=75	1A	1190	1A	D 500	L 350	
						Indices of long slider plate <i>see from pg. US-30 to pg. US-32</i>		
						Indices of double slider plate, <i>distance of the centers of slider plates</i> <i>see from pg. US-30 to pg. US-32</i>		
				Profile/Rail code				
				L= Total length of the unit				
				Driving head code				
		Size		<i>see from pg. US-30 to pg. US-32</i>				
Type								
Uniline prefix								

Ordering example: UE 07 1A 1190 1A D 500 L 350

In order to create identification codes for Actuator Line, you can visit: <http://configureactuator.rollon.com>



**Left / right orientation**

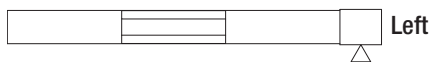

> Accessories

Standard motor adapter plate

E	07	AC2	
	05=55		Standard motor adapter plates <i>see pg. US-35</i>
	07=75		
	Size		<i>see pg. US-35</i>
Type			

Ordering example: E07-AC2

NEMA motor adapter plates

E	07	AC1	
	05=55		NEMA motor adapter plates <i>see pg. US-35</i>
	07=75		
	Size		<i>see pg. US-35</i>
Type			

Ordering example: E07-AC1

**T-connection plate** Order code: APC-1, s. pg. US-36

**Angle connection plate** Order code: APC-2, s. pg. US-37

**X connection plate** Order code: APC-3, s. pg. US-37

**Fixing clamp** Order code: APF-2, s. pg. US-36

Motor connection bores

Hole [Ø]	Size		Head code
	55	75	
<b>Metric [mm]</b> with slot for key	12G8 / 4js9	14G8 / 5js9	1A
	10G8 / 3js9	16G8 / 5js9	2A
	14G8 / 5js9	19G8 / 6js9	3A
	16G8 / 5js9		4A
<b>Metric [mm]</b> for compression coupling		18	1B
		24	2B
<b>Inch [in]</b> with slot for key	1/2 / 1/8	5/8 / 3/16	1P
	3/8 / 1/8		2P
	5/8 / 3/16		3P

Tab. 75

The highlighted connection bores are standard connections

Metric: key seat for keys to DIN 6885 form A

Inch: key seat for keys to BS 46 Part 1: 1958

## Uniline ED series



### > Uniline ED series description

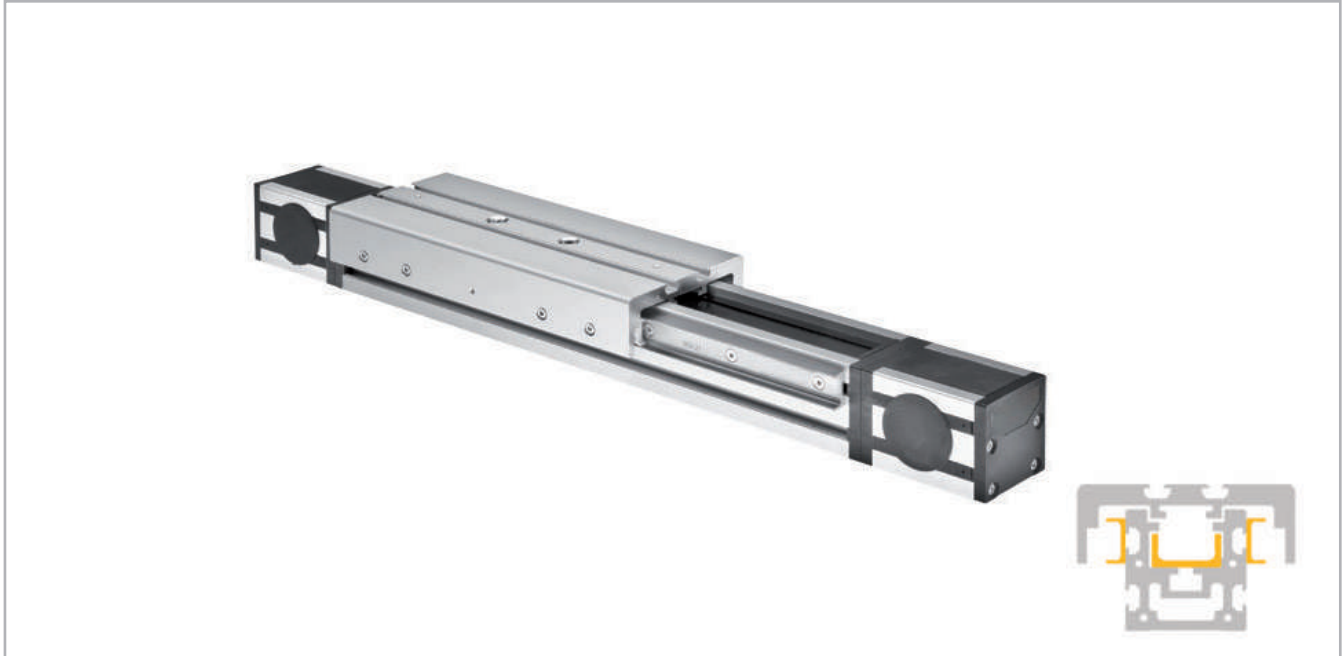

Fig. 59

Uniline is a family of ready-to-install linear actuators. They consist of internal Compact Rail roller sliders and steel-reinforced polyurethane belts in a rigid aluminum profile. Longitudinal seals enclose the system. This arrangement provides the best protection for the actuator from soiling and damage. In the ED series, a compensating bearing rail (U-rail) is mounted horizontally in the aluminum profile, and for increased moment support, two more compensating bearing rails (U-rail) are flanged to the profile externally. Versions with long (L) or double (D) sliders in one axis are possible.

#### The most important characteristics:

- Compact design
- Protected internal linear guides
- High traversing speeds
- Grease-free operation possible (depending on the application. For further information, please contact our Application Engineering department)
- High versatility
- Long strokes
- Versions with long or multiple sliders available in one linear axis

#### Preferred areas of application:

- Handling and automation
- Multi-axis gantries
- Packaging machines
- Cutting machines
- Displaceable panels
- Painting installations
- Welding robots
- Special machines

#### Technical data:

- Available sizes [mm]:  
Type ED: 75
- Length and stroke tolerances:  
For strokes <1 m: +0 mm to +10 mm (+0 in to 0.4 in)  
For strokes >1 m: +0 mm to +15 mm (+0 in to 0.59 in)



## > The components

### Extruded profile

The anodized 6060 aluminum alloy extrusion used for the profile of the Rollon Uniline ED series linear units were designed and manufactured by industry experts to optimize weight while maintaining mechanical strength. (see physical-chemical characteristics below). The dimensional tolerances comply with EN 755-9 standard.

### Driving belt

The Rollon Uniline ED series linear units use steel reinforced polyurethane drive belts with RPP pitch and parabolic profiles. This belt is ideal due to its high load transmission characteristics, compact size and low noise. Used in conjunction with a backlash-free pulley, smooth alternating motion can

be achieved. Optimization of the maximum belt width/body dimension ratio enables the following performance characteristics to be achieved:

- High speed
- Low noise
- Low wear

### Carriage

The carriage of the Rollon Uniline ED series linear units are made entirely of anodized aluminum. Each carriage has mounting T-slots for the connection to the moving element. Rollon offers multiple carriages to accommodate a vast array of applications.

### General data about aluminum used: AL 6060

Chemical composition [%]

Al	Mg	Si	Fe	Mn	Zn	Cu	Impurites
Remaining	0.35-0.60	0.30-0.60	0.30	0.10	0.10	0.10	0.05-0.15

Tab. 76

Physical characteristics

Density	Coeff. of elasticity	Coeff. of thermal expansion (20°-100°C)	Thermal conductivity (20°C)	Specific heat (0°-100°C)	Resistivity	Melting point
$\frac{\text{kg}}{\text{dm}^3}$	$\frac{\text{kN}}{\text{mm}^2}$	$\frac{10^{-6}}{\text{K}}$	$\frac{\text{W}}{\text{m} \cdot \text{K}}$	$\frac{\text{J}}{\text{kg} \cdot \text{K}}$	$\Omega \cdot \text{m} \cdot 10^{-9}$	°C
2.7	69	23	200	880-900	33	600-655

Tab. 77

Mechanical characteristics

Rm	Rp (02)	A	HB
$\frac{\text{N}}{\text{mm}^2}$	$\frac{\text{N}}{\text{mm}^2}$	%	—
205	165	10	60-80

Tab. 78

> ED75

ED75 system

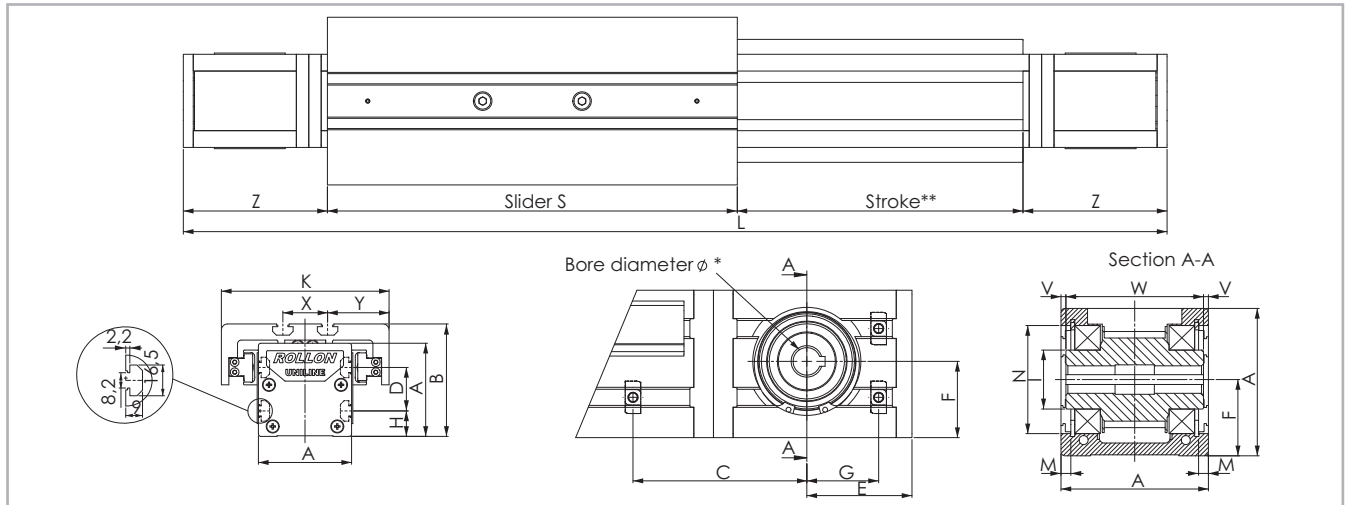

\* For information on the motor connection bores, see ordering key. \*\* The length of the safety stroke is provided on request according to the customer's specific requirements. Fig. 60

Type	A [mm]	B [mm]	C* [mm]	D [mm]	E [mm]	F [mm]	G* [mm]	H [mm]	I [mm]	K [mm]	M [mm]	N [mm]	S [mm]	X [mm]	Y [mm]	V [mm]	W [mm]	Z [mm]	Stroke** [mm]
ED75	75	90	71.5	35	53.5	38.8	34.5	20	Ø 29.5	135	4.85	Ø 55	330	36	49.5	2.3	70.4	116	2900

\* For the position of the T-nuts when using our motor adapter plates, see pg. US-45ff Tab. 79  
 \*\* Maximum stroke for a single-piece guiding rail. For longer strokes, see tab. 84

ED75L with long slider

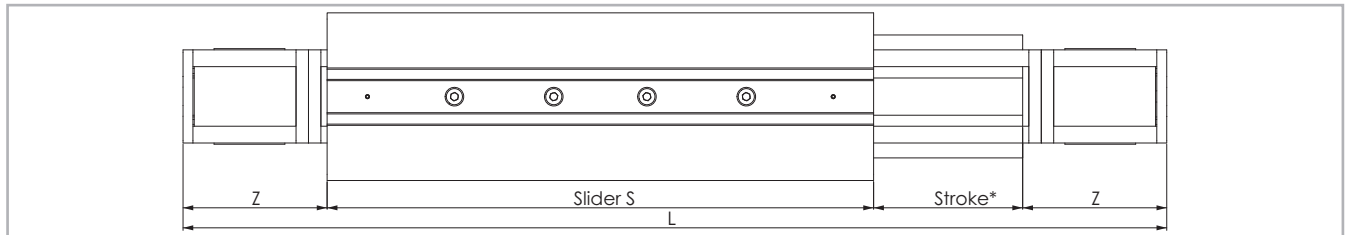

\* The length of the safety stroke is provided on request according to the customer's specific requirements. Fig. 61

Type	$S_{min}^*$ [mm]	$S_{max}$ [mm]	$S_n$ [mm]	Z [mm]	Stroke** [mm]
ED75L	440	700	$S_n = S_{min} + n \cdot 10$	116	2500

\* The length of 440 mm is considered standard, all other lengths are considered special dimensions Tab. 80  
 \*\* Maximum stroke for a single-piece guiding rail and a maximum slider plate length  $S_{max}$ . For longer strokes, see tab. 84

ED75D with double slider

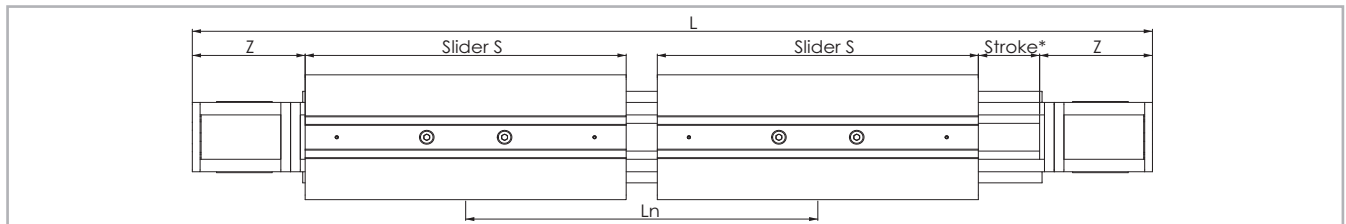

\* The length of the safety stroke is provided on request according to the customer's specific requirements. Fig. 62

Type	S [mm]	$L_{min}$ [mm]	$L_{max}^{**}$ [mm]	$L_n$ [mm]	Z [mm]	Stroke* [mm]
ED75D	330	416	2864	$L_n = L_{min} + n \cdot 8$	116	2450

\* Maximum stroke for a single-piece guiding rail and a minimum slider plate distance  $L_{min}$  Tab. 81  
 \*\* Maximum distance  $L_{max}$  between the centres of slider plates at a stroke of 0 mm. For longer strokes, see tab. 84

Type ED

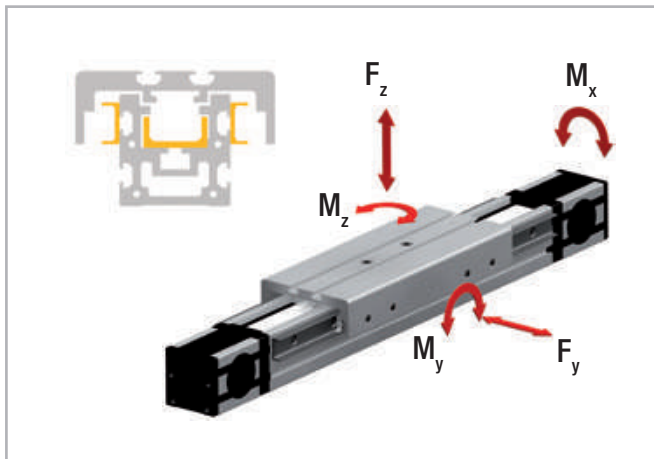

Fig. 63

Driving belt

The driving belt is manufactured from a friction resistant polyurethane and with steel cords for high tensile stress resistance.

Type	Type of belt	Belt width [mm]	Weight [kg/m]
ED75	30RPP8	30	0.185

Tab. 82

Belt length (mm) = 2 x L - 258 Standard slider

Belt length (mm) = 2 x L - S<sub>n</sub> + 72 Long slider

Belt length (mm) = 2 x L - L<sub>n</sub> - 258 Double slider

Type	C [N]	F <sub>y</sub> [N]	F <sub>z</sub> [N]	M <sub>x</sub> [Nm]	M <sub>y</sub> [Nm]	M <sub>z</sub> [Nm]
ED75	9815	5500	8700	400.2	868	209
ED75-L	19630	11000	8700	400.2	1174 to 2305	852 to 2282
ED75-D	19630	11000	17400	800.4	3619 to 24917	2288 to 15752

For the calculation of the allowed moments, please see pages SL-5ff

Tab. 83

Technical data	Type
	ED75
Standard belt tension [N]	1000
Moment at no load [Nm]	1.5
Max. traversing speed [m/s]	5
Max. acceleration [m/s <sup>2</sup> ]	15
Repeat accuracy [mm]	0.1
Compact Rail guiding rail	ULV43 / ULV28
Slider type	CS43 spec. / CS28 spec.
Moment of inertia I <sub>y</sub> [cm <sup>4</sup> ]	127
Moment of inertia I <sub>z</sub> [cm <sup>4</sup> ]	172
Pitch diameter of pulley [m]	0.05093
Moment of inertia of each pulley [gmm <sup>2</sup> ]	139969
Stroke per shaft revolution [mm]	160
Mass of slider [g]	3770
Weight with zero stroke [g]	9850
Weight with 1 m stroke [g]	14400
Max. stroke [mm]	7500
Working temperature	from -20 °C to + 80 °C

Tab. 84

## > Lubrication

The raceways of the guide rails in the Uniline linear axes are prelubricated. To achieve the calculated service life, a lubrication film must always be present between the raceway and the roller. The lubrication film also provides anticorrosion protection to the ground raceways. An approximate value for the lubrication period is every 100 km or every six months. The recommended lubricant is a lithium-based roller bearing grease of medium consistency.

### Lubrication of the raceways

Proper lubrication under normal conditions:

- reduces friction
- reduces wear
- reduces stress on the contact faces
- reduces running noise

Lubricants	Thickeners	Temperature range [°C]	Dynamic viscosity [mPas]
Roller bearing grease	Lithium soap	-30 to +170	<4500

Tab. 85

### Relubrication of the guide rails

1. Slide the slider plate to one end of the unit.
2. At about half the stroke press and manually move the belt in order to see one of the two rails inside the unit (see Fig. 64).  
It may be necessary to release or loosen the belt tension. See chapter Belt tension (pg. US-59).
3. By using a grease syringe (not supplied by ROLLON) or an alternative tool (i.e. brush), apply a sufficient quantity of grease on the raceways.
4. If required, re-establish the recommended belt tension (see pg. US-59).
5. Finally slide the slider plate back and forth over the entire stroke, in order to distribute the grease over the entire length of the rail.

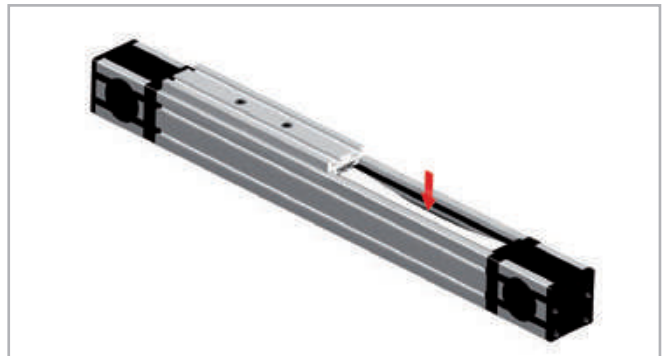

Fig. 64

### Cleaning the guide rails

It is always recommended to clean the slider rail prior to any relubrication, in order to remove grease residues. This can be done while performing maintenance work or during a scheduled machine stop.

1. Unscrew the safety screws C (on top of the slider plate) from the belt tensioning device A (see fig. 65).
2. Also completely unscrew the belt tensioning screws B and remove the belt tensioning devices A from their housings.
3. Lift the toothed belt until the guide rails can be seen.  
Important: Ensure that the side seal is not damaged.
4. Clean the rail raceways with a clean and dry cloth. Ensure that all grease and dirt residues from previous work processes are removed.  
To ensure that the rails are cleaned over their entire length, the slider plate should be moved once over its entire length.
5. Apply a sufficient amount of grease to the raceways.

6. Re-insert the belt tensioning devices A into their housings and mount the belt tensioning screws B. Re-adjust the belt tension (see pg. US-59).
7. Fasten the safety screws C.

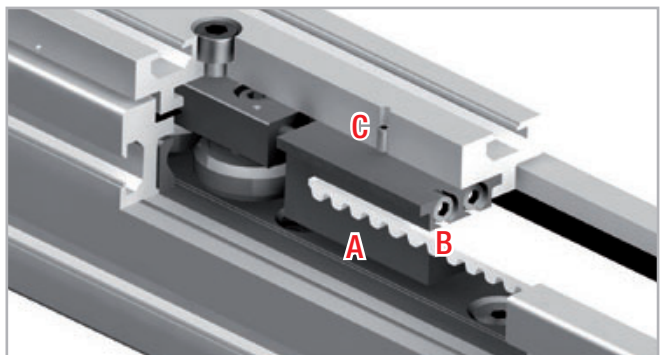

Fig. 65

## > Accessories

### Adapter plates

#### Standard motor adapter plates AC2

Mounting plates for the most common motors or gearboxes. The connection bores for the motors or gearboxes must be made on site. All plates are delivered with M6 x 10 screws to DIN 912 and T-nuts for mounting on the linear units.

\* Area of plate needs to be cut if used for ED75 linear unit. (Adding 20 mm to total length of unit will render this modification unnecessary). Otherwise it gets in contact with the outer rail.  
X = 20 mm; Y = 35 mm

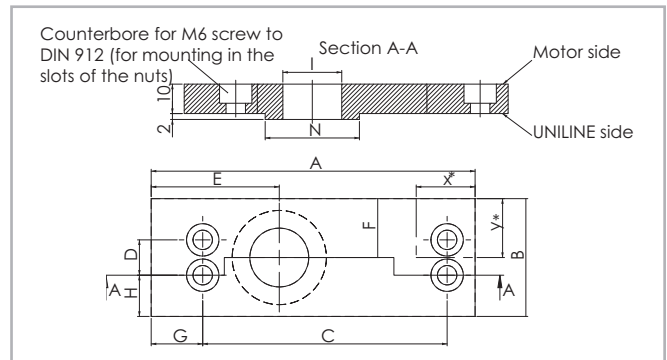

Fig. 66

Size	A [mm]	B [mm]	C [mm]	D [mm]	E [mm]	F [mm]	G [mm]	H [mm]	I [mm]	N [mm]
75	135	70	106	35	53.5	35	19	17.5	Ø 35	Ø 55

Tab. 86

#### NEMA plates AC1-P

Mounting plates for NEMA motors or gearboxes. These plates are delivered ready-to-mount on the linear axes. All plates are delivered with M6 x 10 screws to DIN 912 and T-nuts for mounting on the linear units.

Size	NEMA Motors / Gearboxes
75	NEMA 42

Tab. 87

\* Area of plate needs to be cut if used for ED75 linear unit. (Adding 20 mm to total length of unit will render this modification unnecessary). Otherwise it gets in contact with the outer rail.  
X = 20 mm; Y = 60 mm

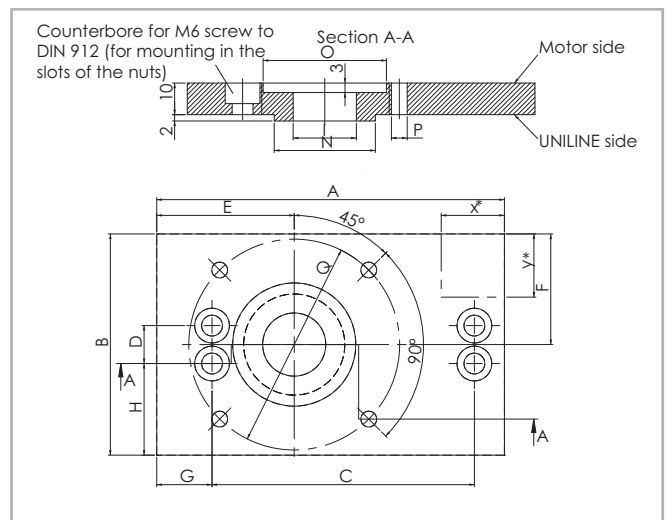

Fig. 67

Size	A [mm]	B [mm]	C [mm]	D [mm]	E [mm]	F [mm]	G [mm]	H [mm]	I [mm]	N [mm]	O [mm]	P [mm]	Q [mm]
75	135	120	106	35	53.5	60	19	42.5	35	Ø 55	Ø 57	Ø 7.1	Ø 125.7

Tab. 88

#### Synchronous use of linear axes in pairs

If two axes are to be used in parallel using a connecting shaft, please specify when ordering, to ensure that the key slots of the pulleys are synchronized.

**Fixing brackets APF-2**

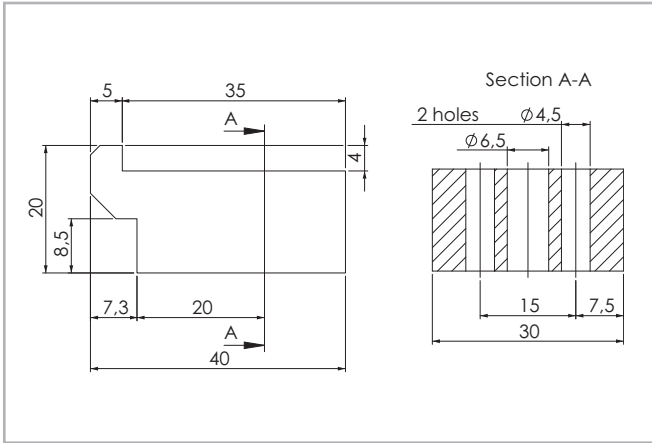

Fig. 68

Fixing clamp for simple mounting of a linear axis on a mounting surface or for connecting two units with or without a connection plate (see pg. US-63).

A spacer\* may be necessary.

\*(Any spacer that may be necessary must be manufactured on site)

**T-nut**

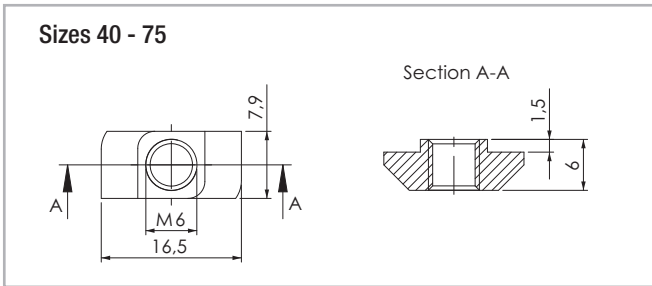

Fig. 69

The maximum tightening torque is 10 Nm.

**Assembly kits**

**T-connection plate APC-1**

T-connection plate allows two units to be mounted perpendicular to each other (see pg. US-60). The plate will not interfere with the strokes of either unit. All plates are delivered with M6 x 10 screws to DIN 912 and T-nuts for mounting on the linear units.

**Note**

In case of use of APC-1 plates with E and ED series, please consult Rollon Technical Dpt. In standard there is an interference between U-rail and APC-1 plate. A special version with shorter U-rail at both extremities will be offered.

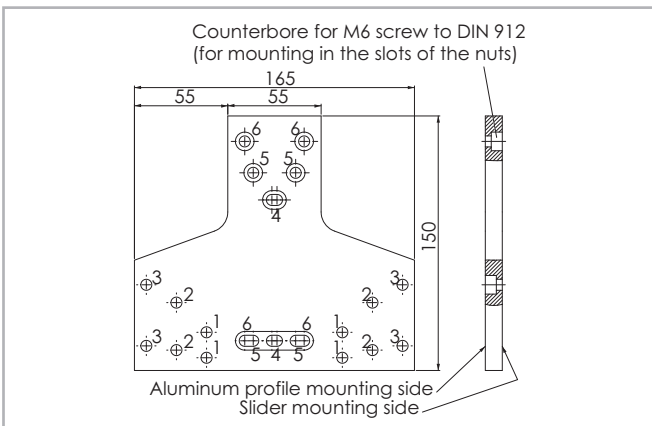

Fig. 70

Size	Fixing holes for the slider	Fixing holes for the profile
75	Holes 3	Holes 6

Tab. 89

**Angle connection plate APC-2**

allows the right angle mounting of two units. The trolley of one unit can be mounted to the side of the other (see pg. US-61). The plate will not interfere with the strokes of either unit. All plates are delivered with M6 x 10 screws to DIN 912 and T-nuts for mounting to the linear units.

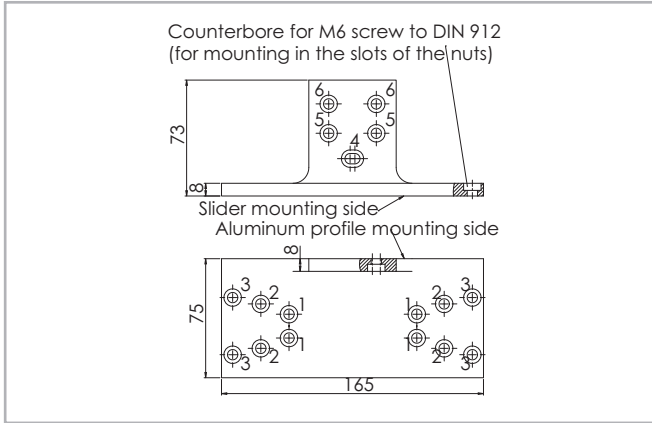

Fig. 71

**Note**

This adapter plate can be used with types E and ED only to a limited extent. For further information, please contact our Application Engineering Department.

Size	Fixing holes for the slider	Fixing holes for the profile
75	Holes 3	Holes 6

Tab. 90

**X connection plate APC-3**

X connection plate for mounting two sliders perpendicular to each other (see pg. US-62). The plate will not interfere with the strokes of either unit. All plates are delivered with M6 x 10 screws to DIN 912 and T-nuts for mounting on the linear units.

Size	Fixing holes for slider 1	Fixing holes for slider 2
75	Holes 3	Holes 6

Tab. 91

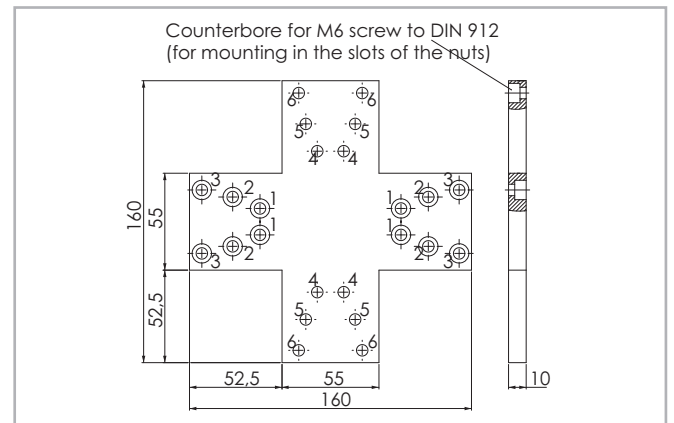
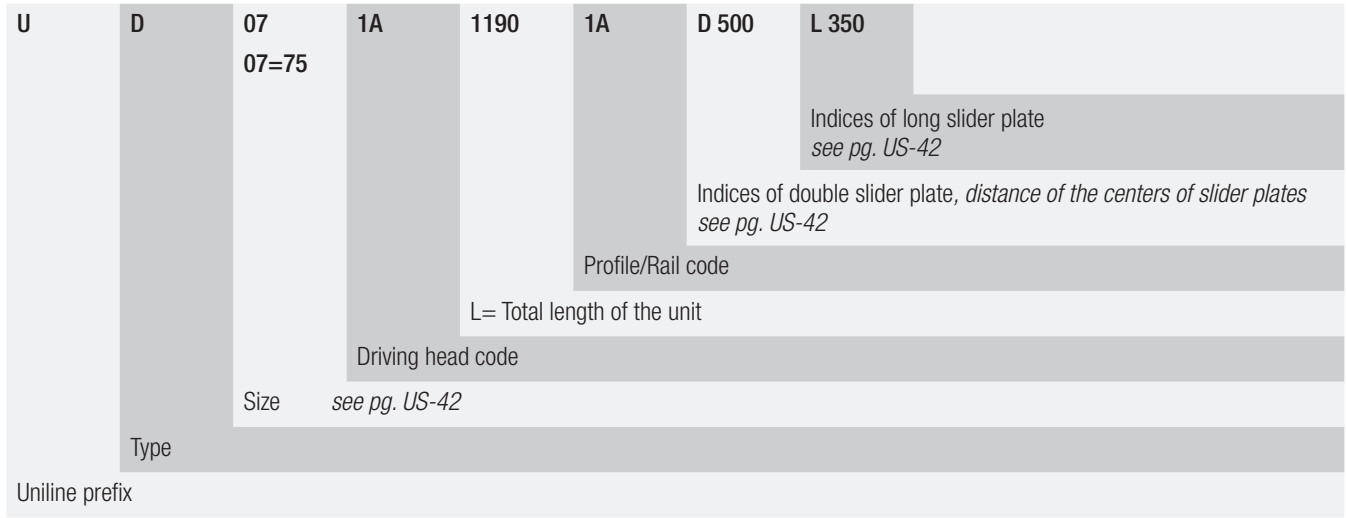

Fig. 72

# Ordering key

## > Identification code for Uniline linear unit



Ordering example: UD 07 1A 1190 1A D 500 L 350

In order to create identification codes for Actuator Line, you can visit: <http://configureactuator.rollon.com>



### Left / right orientation

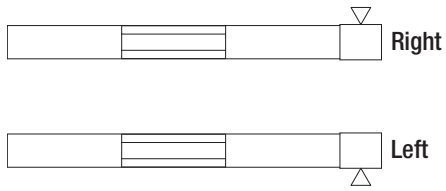



## > Accessories

### Standard motor adapter plate

D	07	AC2	
	07=75	Standard motor adapter plates	see pg. US-45
	Size	see pg. US-45	
Type			

Ordering example: D07-AC2

### NEMA motor adapter plates

D	07	AC1	
	07=75	NEMA motor adapter plates	see pg. US-45
	Size	see pg. US-45	
Type			

Ordering example: D07-AC1

**T-connection plate**      Order code: APC-1, s. pg. US-46

**Angle connection plate**      Order code: APC-2, s. pg. US-47

**X connection plate**      Order code: APC-3, s. pg. US-47

**Fixing clamp**      Order code: APF-2, s. pg. US-46

### Motor connection bores

	Size	Head code
Hole [Ø]	75	
<b>Metric [mm]</b> with slot for key	14G8 / 5js9	1A
	16G8 / 5js9	2A
	19G8 / 6js9	3A
		4A
<b>Metric [mm]</b> for compression coupling	18	1B
	24	2B
<b>Inch [in]</b> with slot for key	5/8 / 3/16	1P
		2P
		3P

Tab. 92

The highlighted connection bores are standard connections

Metric: key seat for keys to DIN 6885 form A

Inch: key seat for keys to BS 46 Part 1: 1958

## Uniline H series



### > Uniline H series description



Fig. 73

Uniline is a family of ready-to-install linear actuators. They consist of internal Compact Rail roller sliders in a rigid aluminum profile. Longitudinal seals enclose the system. This arrangement provides the best protection for the actuator from soiling and damage. In the H series, the compensating bearing rail (U-rail) is mounted horizontally in the aluminum profile. The H series is used as a compensating bearing axis for load absorption of radial forces, and in combination with the other series, as support bearing for the resulting moments. Versions with long (L) or double (D) sliders in one axis are possible. H series is a slave actuator, it has not the driving belt.

#### The most important characteristics:

- Compact design
- Protected internal linear guides
- High traversing speeds
- Grease-free operation possible (depending on the application. For further information, please contact our Application Engineering department)
- High versatility
- Long strokes
- Versions with long or multiple sliders available in one linear axis

#### Preferred areas of application:

- Handling and automation
- Multi-axis gantries
- Packaging machines
- Cutting machines
- Displaceable panels
- Painting installations
- Welding robots
- Special machines

#### Technical data:

- Available sizes [mm]:  
Type H: 40, 55, 75
- Length and stroke tolerances:  
For strokes <1 m: +0 mm to +10 mm (+0 in to 0.4 in)  
For strokes >1 m: +0 mm to +15 mm (+0 in to 0.59 in)

## > The components

### Extruded profile

The anodized 6060 aluminum alloy extrusion used for the profile of the Rollon Uniline series linear units were designed and manufactured by industry experts to optimize weight while maintaining mechanical strength. (see physical-chemical characteristics below). The dimensional tolerances comply with EN 755-9 standard.

### Carriage

The carriage of the Rollon Uniline H series linear units are made entirely of anodized aluminum. Each carriage has mounting T-slots for the connection to the moving element. Rollon offers multiple carriages to accommodate a vast array of applications.

### General data about aluminum used: AL 6060

Chemical composition [%]

Al	Mg	Si	Fe	Mn	Zn	Cu	Impurities
Remaining	0.35-0.60	0.30-0.60	0.30	0.10	0.10	0.10	0.05-0.15

Tab. 93

Physical characteristics

Density	Coeff. of elasticity	Coeff. of thermal expansion (20°-100°C)	Thermal conductivity (20°C)	Specific heat (0°-100°C)	Resistivity	Melting point
$\frac{\text{kg}}{\text{dm}^3}$	$\frac{\text{kN}}{\text{mm}^2}$	$\frac{10^{-6}}{\text{K}}$	$\frac{\text{W}}{\text{m} \cdot \text{K}}$	$\frac{\text{J}}{\text{kg} \cdot \text{K}}$	$\Omega \cdot \text{m} \cdot 10^{-9}$	°C
2.7	69	23	200	880-900	33	600-655

Tab. 94

Mechanical characteristics

Rm	Rp (02)	A	HB
$\frac{\text{N}}{\text{mm}^2}$	$\frac{\text{N}}{\text{mm}^2}$	%	—
205	165	10	60-80

Tab. 95

> H40

H40 system

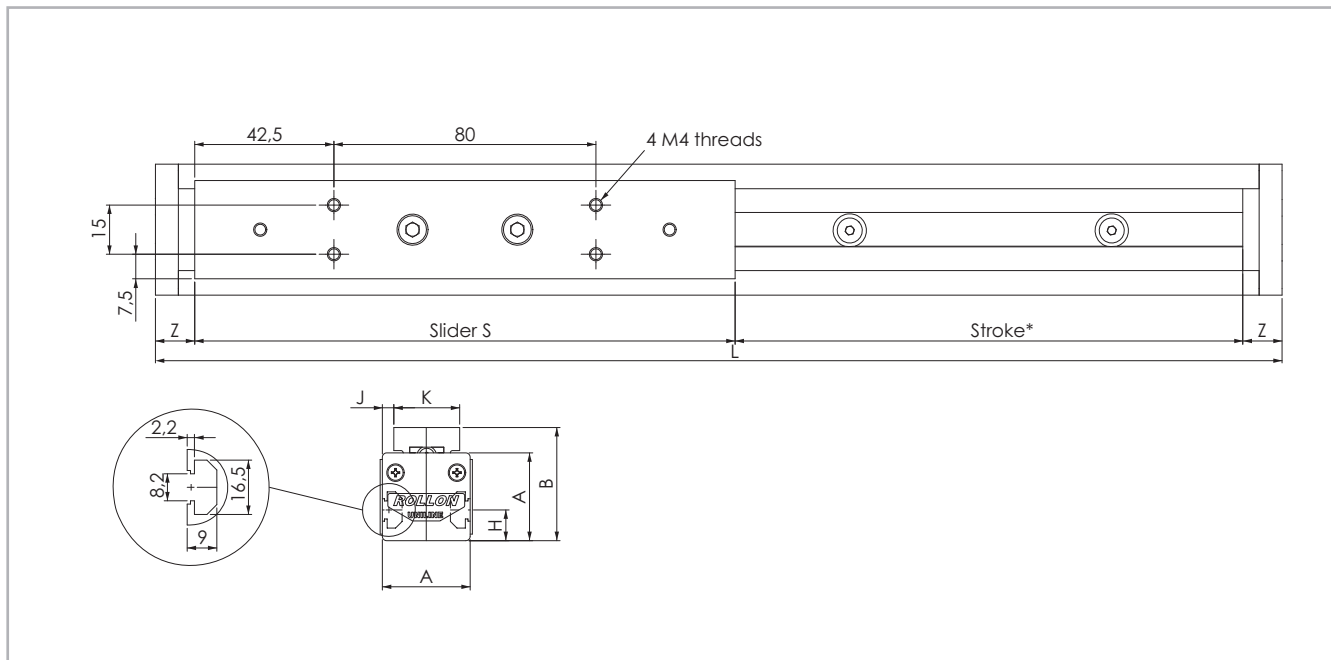

\* The length of the safety stroke is provided on request according to the customer's specific requirements.

Fig. 74

Type*	A [mm]	B <sub>nom</sub> [mm]	B <sub>min</sub> [mm]	B <sub>max</sub> [mm]	D [mm]	H [mm]	J [mm]	K [mm]	S [mm]	X [mm]	Y [mm]	Z [mm]	Stroke** [mm]
H40	40	51.5	51.2	52.6	-	14	5	30	165	-	-	12	1900

\* Including long or double slider. See chapter 3 Product dimensions Types A...L and A...D  
 \*\* Maximum stroke for a single-piece guiding rail. For longer strokes, see tab. 98

Tab. 96

H40

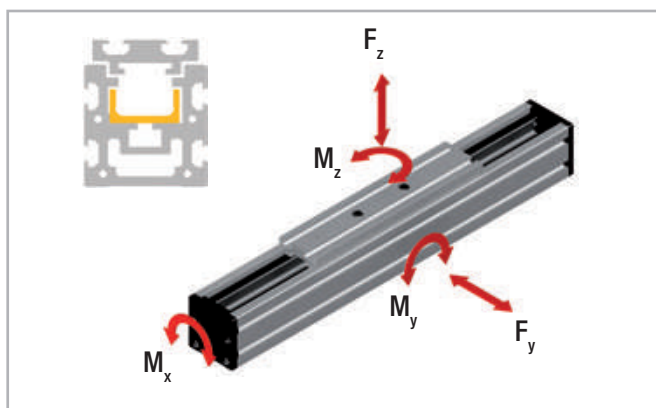

Fig. 75

Type	C [N]	F <sub>y</sub> [N]	F <sub>z</sub> [N]	M <sub>x</sub> [Nm]	M <sub>y</sub> [Nm]	M <sub>z</sub> [Nm]
H40	1530	820				13.1
H40-L	3060	1640	0	0	0	61 to 192
H40-D	3060	1640				192 to 1558

For the calculation of the allowed moments, please see pages SL-5ff

Tab. 97

Technical data	Type
	H40
Max. traversing speed [m/s]	3
Max. acceleration [m/s <sup>2</sup> ]	10
Repeat accuracy [mm]	0.1
Compact Rail guiding rail	ULV18
Slider type	CS18 spec.
Moment of inertia I <sub>y</sub> [cm <sup>4</sup> ]	12
Moment of inertia I <sub>z</sub> [cm <sup>4</sup> ]	13.6
Mass of slider [g]	220
Weight with zero stroke [g]	860
Weight with 1 m stroke [g]	3383
Max. stroke [mm]	3500
Working temperature	from -20 °C to + 80 °C

Tab. 98

> H55

H55 system

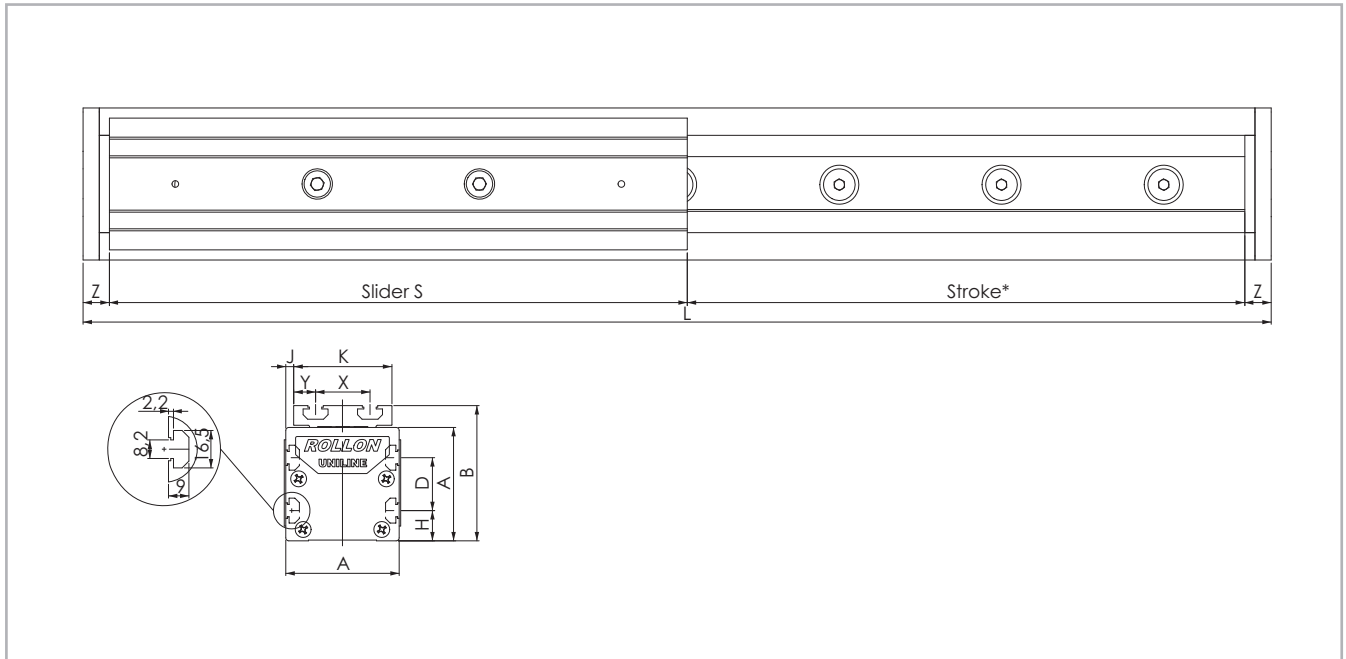

\* The length of the safety stroke is provided on request according to the customer's specific requirements.

Fig. 76

Type*	A [mm]	B <sub>nom</sub> [mm]	B <sub>min</sub> [mm]	B <sub>max</sub> [mm]	D [mm]	H [mm]	J [mm]	K [mm]	S [mm]	X [mm]	Y [mm]	Z [mm]	Stroke** [mm]
H55	55	71	70.4	72.3	25	15	1.5	52	200	28	12	13	3070

\* Including long or double slider. See chapter 3 Product dimensions Types A...L and A...D

\*\* Maximum stroke for a single-piece guiding rail. For longer strokes, see tab. 101

Tab. 99

H55

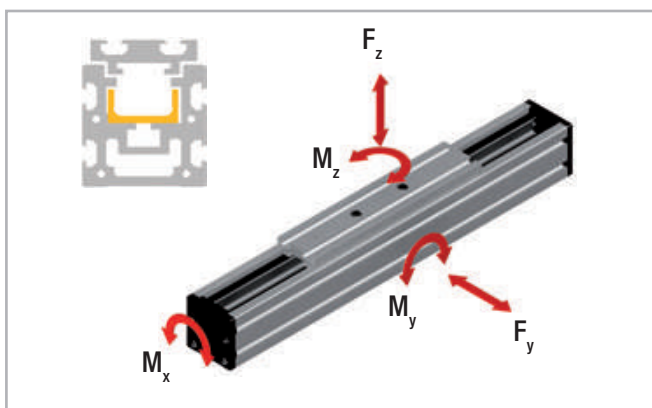

Fig. 77

Type	C [N]	F <sub>y</sub> [N]	F <sub>z</sub> [N]	M <sub>x</sub> [Nm]	M <sub>y</sub> [Nm]	M <sub>z</sub> [Nm]
H55	4260	2175				54.5
H55-L	8520	4350	0	0	0	239 to 652
H55-D	8520	4350				652 to 6677

For the calculation of the allowed moments, please see pages SL-5ff

Tab. 100

Technical data	Type
	H55
Max. traversing speed [m/s]	5
Max. acceleration [m/s <sup>2</sup> ]	15
Repeat accuracy [mm]	0.1
Compact Rail guiding rail	ULV28
Slider type	CS28 spec.
Moment of inertia I <sub>y</sub> [cm <sup>4</sup> ]	34.6
Moment of inertia I <sub>z</sub> [cm <sup>4</sup> ]	41.7
Mass of slider [g]	475
Weight with zero stroke [g]	1460
Weight with 1 m stroke [g]	4357
Max. stroke [mm]	5500
Working temperature	from -20 °C to + 80 °C

Tab. 101

> H75

H75 system

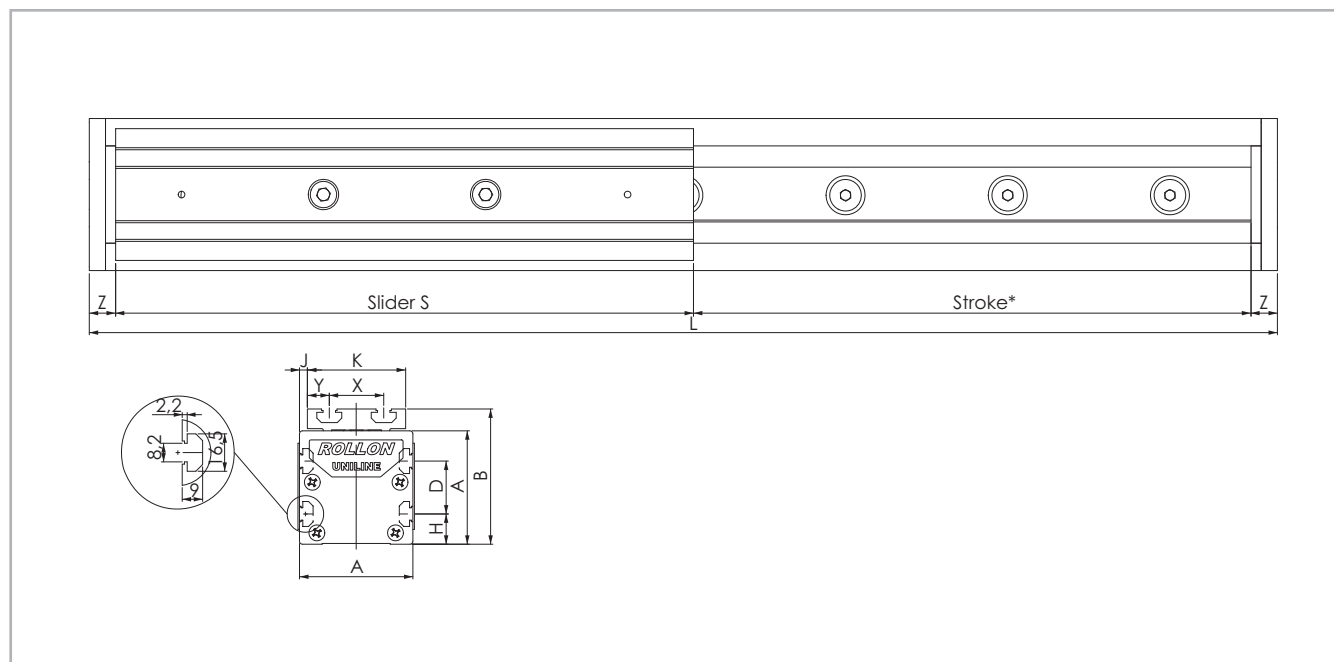

\* The length of the safety stroke is provided on request according to the customer's specific requirements.

Fig. 78

Type*	A [mm]	B <sub>nom</sub> [mm]	B <sub>min</sub> [mm]	B <sub>max</sub> [mm]	D [mm]	H [mm]	J [mm]	K [mm]	S [mm]	X [mm]	Y [mm]	Z [mm]	Stroke** [mm]
H75	75	90	88.6	92.5	35	20	5	65	285	36	14.5	13	3420

\* Including long or double slider. See chapter 3 Product dimensions Types A...L and A...D

\*\* Maximum stroke for a single-piece guiding rail. For longer strokes, see tab. 104

Tab. 102

H75

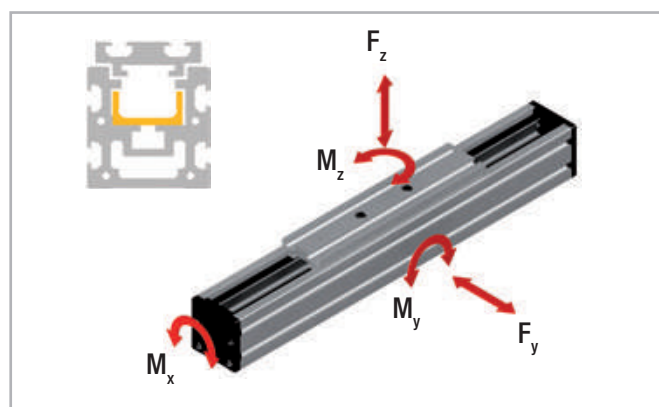

Fig. 79

Type	C [N]	F <sub>y</sub> [N]	F <sub>z</sub> [N]	M <sub>x</sub> [Nm]	M <sub>y</sub> [Nm]	M <sub>z</sub> [Nm]
H75	12280	5500				209
H75-L	24560	11000	0	0	0	852 to 2282
H75-D	24560	11000				2288 to 18788

For the calculation of the allowed moments, please see pages SL-5ff

Tab. 103

Technical data	Type
	H75
Max. traversing speed [m/s]	7
Max. acceleration [m/s <sup>2</sup> ]	15
Repeat accuracy [mm]	0.1
Compact Rail guiding rail	ULV43
Slider type	CS43 spec.
Moment of inertia I <sub>y</sub> [cm <sup>4</sup> ]	127
Moment of inertia I <sub>z</sub> [cm <sup>4</sup> ]	172
Mass of slider [g]	1242
Weight with zero stroke [g]	4160
Weight with 1 m stroke [g]	9381
Max. stroke [mm]	7500
Working temperature	from -20 °C to + 80 °C

Tab. 104

## > Lubrication

The raceways of the guide rails in the Uniline linear axes are prelubricated. To achieve the calculated service life, a lubrication film must always be present between the raceway and the roller. The lubrication film also provides anticorrosion protection to the ground raceways. An approximate value for the lubrication period is every 100 km or every six months. The recommended lubricant is a lithium-based roller bearing grease of medium consistency.

### Lubrication of the raceways

Proper lubrication under normal conditions:

- reduces friction
- reduces wear
- reduces stress on the contact faces
- reduces running noise

Lubricants	Thickeners	Temperature range [°C]	Dynamic viscosity [mPas]
Roller bearing grease	Lithium soap	-30 to +170	<4500

Tab. 105

### Relubrication of the guide rails

These types of rails have a lubricating conduit on the side of the slider plate through which the lubricant can be applied directly to the raceways. Lubrication can be done in one of two ways:

#### 1. Relubrication using a grease gun:

This is done by inserting the tip of the grease gun into the conduit at the slider plate and injecting the grease inside (see fig. 80). Please note that the grease has to fill the whole conduit in order to lubricate the rail properly; for this reason sufficient grease must be used.

#### 2. Automatic lubrication system:

To connect the unit to an automatic greasing system, use a proper adapter/connector\* that attaches to the threaded hole on the side of the trolley.

The advantage of this solution is the possibility of rail re-lubrication without machine downtime.

\*(Any adapter that may be necessary must be manufactured on site)

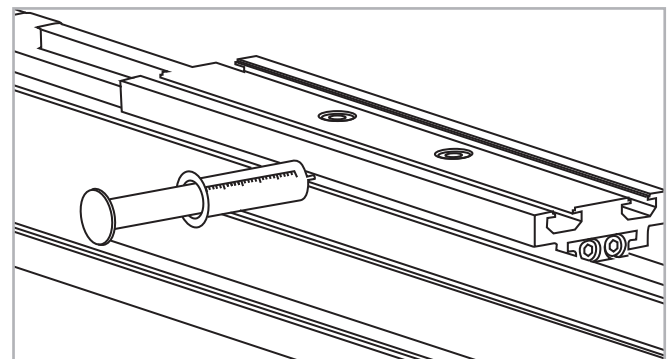

Fig. 80

### Cleaning the guide rails

It is always recommended to clean the slider rail prior to any relubrication, in order to remove grease residues. This can be done while performing maintenance work or during a scheduled machine stop.

#### 1. Clean the rail raceways with a clean and dry cloth. Ensure that all grease and dirt residues from previous work processes are removed.

To ensure that the rails are cleaned over their entire length, the slider plate should be moved once over its entire length.

#### 2. Apply a sufficient amount of grease to the raceways.

> Accessories

Fixing brackets APF-2

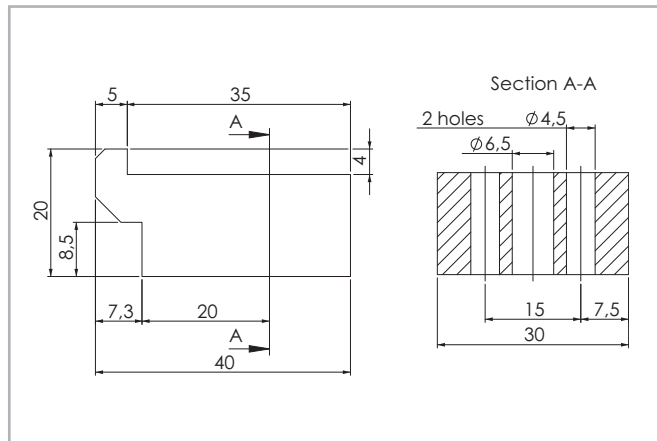

Fig. 81

Fixing clamp for simple mounting of a linear axis on a mounting surface or for connecting two units with or without a connection plate (see pg. US-63).

A spacer\* may be necessary.

\*(Any spacer that may be necessary must be manufactured on site)

T-nut

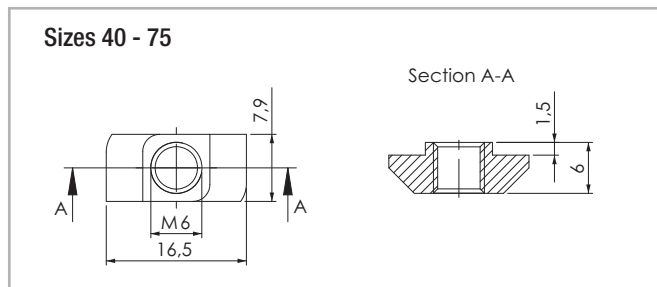

Fig. 82

The maximum tightening torque is 10 Nm.

Assembly kits

T-connection plate APC-1

T-connection plate allows two units to be mounted perpendicular to each other (see pg. US-60). The plate will not interfere with the strokes of either unit. All plates are delivered with M6 x 10 screws to DIN 912 and T-nuts for mounting on the linear units.

Note

In case of use of APC-1 plates with E and ED series, please consult Rollon Technical Dpt. In standard there is an interference between U-rail and APC-1 plate. A special version with shorter U-rail at both extremities will be offered.

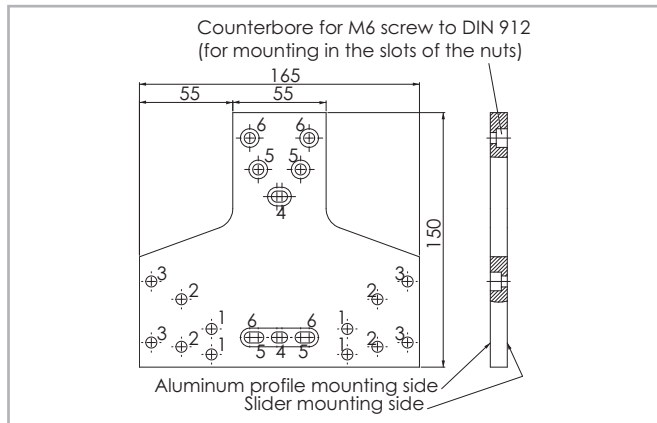

Fig. 83

Size	Fixing holes for the slider	Fixing holes for the profile
40	Holes 1	Holes 4
55	Holes 2	Holes 5
75	Holes 3	Holes 6

Tab. 106



**Angle connection plate APC-2**

allows the right angle mounting of two units. The trolley of one unit can be mounted to the side of the other (see pg. US-61). The plate will not interfere with the strokes of either unit. All plates are delivered with M6 x 10 screws to DIN 912 and T-nuts for mounting to the linear units.

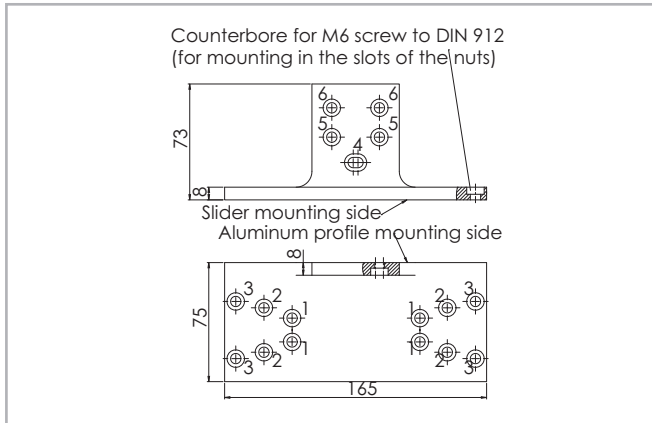

Fig. 84

Size	Fixing holes for the slider	Fixing holes for the profile
40	Holes 1	Holes 4
55	Holes 2	Holes 5
75	Holes 3	Holes 6

Tab. 107

**X connection plate APC-3**

X connection plate for mounting two sliders perpendicular to each other (see pg. US-62). The plate will not interfere with the strokes of either unit. All plates are delivered with M6 x 10 screws to DIN 912 and T-nuts for mounting on the linear units.

Size	Fixing holes for slider 1	Fixing holes for slider 2
40	Holes 1	Holes 4
55	Holes 2	Holes 5
75	Holes 3	Holes 6

Tab. 108

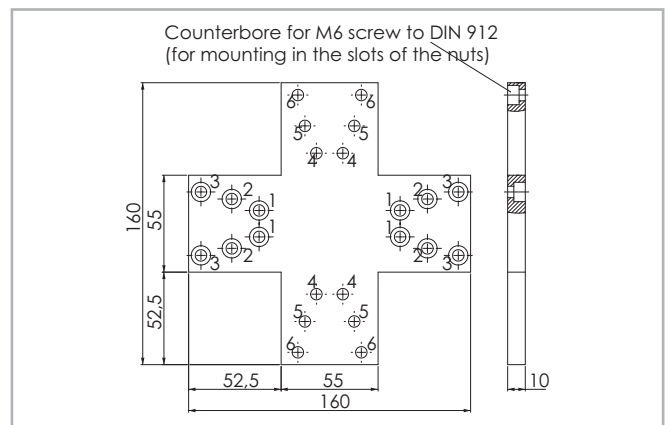

Fig. 85

# Ordering key

## > Identification code for Uniline linear unit

U	H	07 04=40 05=55 07=75	1190	1A	D 500	L 350	
						Indices of long slider plate <i>see pg. US-52 - US-53 - US-54</i>	
						Indices of double slider plate, <i>distance of the centers of slider plates</i> <i>see pg. US-52 - US-53 - US-54</i>	
				Profile/Rail code			
		L= Total length of the unit					
		Size <i>see pg. US-52 - US-53 - US-54</i>					
		Type					
Uniline prefix							

Ordering example: UH 07 1H 1190 1A D 500 L 350

In order to create identification codes for Actuator Line, you can visit: <http://configureactuator.rollon.com>



### Left / right orientation

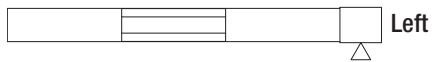

# Belt tension

All Uniline linear axes are all supplied with a standard belt tension suitable for most applications (see tab. 109).

Size	40	55	75	ED75
Belt tension [N]	160	220	800	1000

Tab. 109

The belt tensioning system (located at the ends of the slider plates for sizes 45 to 75) allows the toothed belt tension to be set in accordance with requirements.

To set the belt tension for sizes 40 to 75, the following steps must be followed (the reference values are standard values):

1. Determine the deviation of the belt tension from the standard value.
2. Figures 87 and 88 show how many turns the belt tensioning screws B must be for the required belt tension deviation.
3. Calculate the length of the belt (m), with the formula:  
 $L = 2 \times \text{stroke (m)} + 0.515 \text{ m (size 40);}$   
 $L = 2 \times \text{stroke (m)} + 0.630 \text{ m (size 55);}$   
 $L = 2 \times \text{stroke (m)} + 0.792 \text{ m (size 75).}$
4. Multiply the number of turns (see step 2) by the toothed belt length m (see step 3) to calculate the required number of turns to achieve the new desired belt tension..
5. Unscrew the safety screw C.
6. Turn the belt tensioning screws B in accordance with the above explanation. Re-tighten the safety screw C.

**Example:**

- Increasing the belt tension from 220 N to 330 N for an A55 - 1070:
1. deviation = 330 N - 220 N = 110 N.
  2. Figures 87 and 88 show that the value by which the belt tensioning screws B must be turned to increase the belt tension by 110 N is 0.5 turns.
  3. Formula for calculating the toothed belt length:  
 $L = 2 \times \text{stroke (m)} + 0.630 \text{ m} = 2 \times 1.070 + 0.630 = 2.77 \text{ m.}$

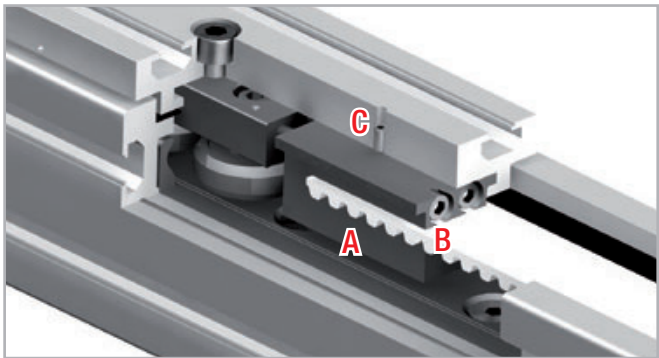

Fig. 86

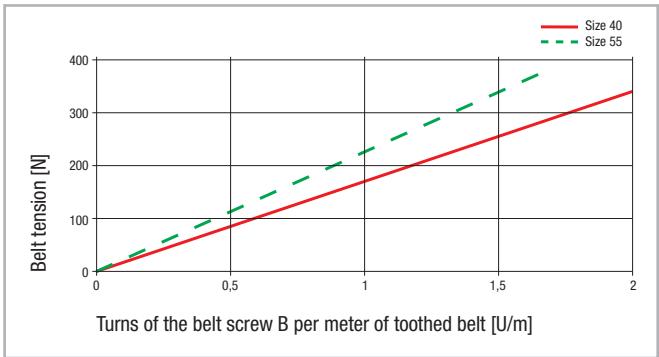

Fig. 87

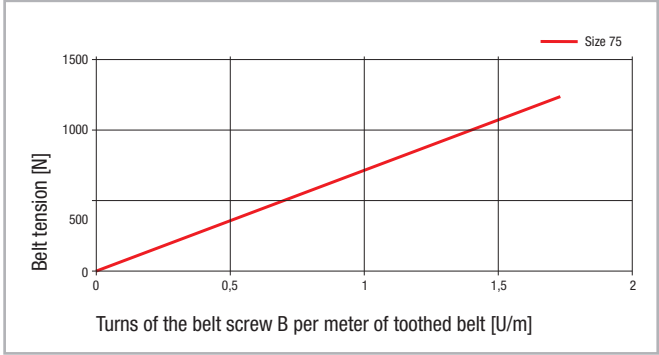

Fig. 88

4. This means that the required number of turns is:  
 $0.5 \text{ rpm} \times 2.77 \text{ m} = 1.4 \text{ turns.}$
5. Unscrew the safety screw C.
6. Turn the belt tensioning screws B by 1.4 turns with the aid of an external reference.
7. Re-tighten the safety screw C.

**Note:**

If the linear unit is used such that the load acts directly on the toothed belt, it is important not to exceed the specified values for the belt tension. Otherwise, the positional accuracy and stability of the toothed belt cannot be guaranteed. If higher values are required for the belt tension, please contact our Application Engineering Department.

## Installation instructions



### Motor adapter plates AC2 and AC1-P, sizes 40 - 75

To connect the linear units to the motor and gearbox, suitable adapter plates must be used. Rollon offers these plates in two different designs (see chapter Accessories). The standard plates are already provided with the holes required for mounting to the linear unit. The fixing holes must be made on site. Ensure that the mounted plate will not interfere with the stroke of the traversing slider plate.

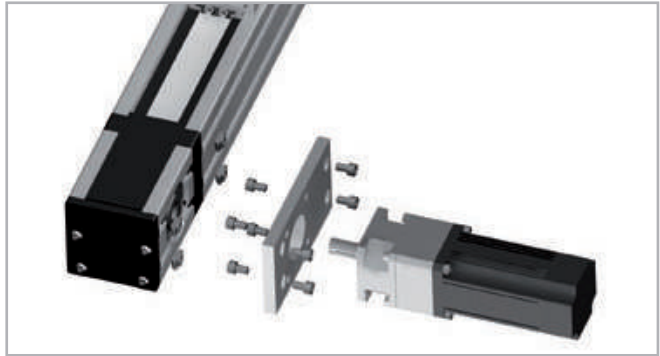

Fig. 89

### Connection to motor and gearbox

1. Attach the motor adapter plate to the motor or gearbox.
2. Connect the T-nuts by inserting the screws without tightening them and align the nuts in parallel to the slots of the unit.
3. Insert the connecting shaft into the drive head by aligning the key in the key slot.
4. Attach the motor adapter plate to the drive head of the linear axis by means of nuts and make sure that the nuts in the slots were rotated by 90° (see Accessories). Ensure correct fit of the adapter plate.

### Note:

- The connecting plates for the Uniline A40 are delivered with four fixing holes, even though only two holes are required for the connection. The presence of four holes give the plate a symmetric design which allows it to be used on any side of the unit.
- Due to the constructive design of the aluminum profile, only three fixing holes can be used for the Uniline C series. (see pg. US-18, fig. 24).

### T-connection plate APC-1, sizes 40 - 75

Connection of two linear axes is achieved by means of the T-connection plate APC-1 (see chapter Accessories). To mount the above-mentioned configuration, the following steps should be carried out:

1. Prepare the connection plate by inserting the screws into the existing holes on the APC-1 (see fig. 90).
2. Connect the T-nuts by introducing the screws without tightening them and align the nuts in parallel to the slots of the unit.
3. Place the plate against the long side of unit 1 and tighten the screws. Ensure that the nuts in the slots were rotated by 90°.
4. To fasten the plate to unit 2, insert the screws from the the long side of unit 1 (see fig. 91).
5. Connect the T-nuts by introducing the screws without tightening them and align the nuts in parallel to the slots of the slider plate of unit 2.
6. Place the plate against the slider plate and tighten the screws. Important: Please make sure that the nuts in the slots were rotated by 90°.

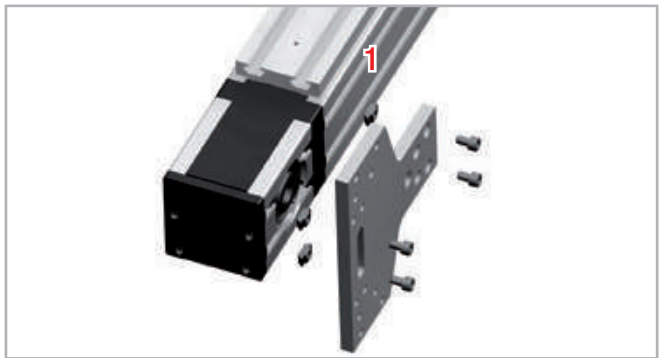

Fig. 90

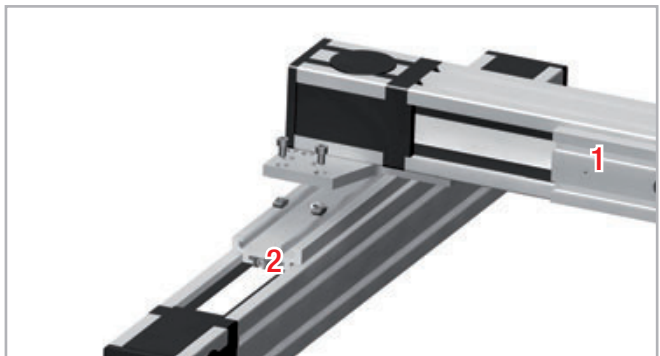

Fig. 91

### Example 1: System consisting of 2 X-axes and 1 Y-axis

The connection of the two units is attained by means of the parallel slider plates and the drive heads. For this configuration, we recommend using our connection plate APC-1.



Fig. 92

### Angle connection plate APC-2, sizes 40 - 75

Connection of two linear axes is achieved by means of the angle connection plate APC-2. To mount the above-mentioned configuration, the following steps should be carried out:

1. Insert the screws to be used for the connection to unit 1 into the prepared holes (see fig. 93).
2. Connect the T-nuts by inserting the screws without tightening them and align the nuts in parallel to the slots of the slider plates.
3. Place the connection plate against the slider plate and tighten the screws. Ensure that the nuts in the slots were rotated by 90°.
4. To fix the connection plate to unit 2, insert the screws into the prepared holes on the short plate side (see fig. 94).
5. Connect the T-nuts by inserting the screws without tightening them and align the nuts in parallel to the slots of the aluminum profile of unit 2.
6. Place the connection plate against the slider plate and tighten the screws. Ensure that the nuts in the slots were rotated by 90°.

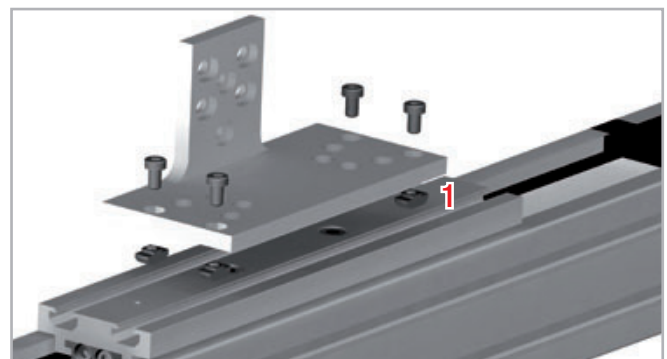

Fig. 93

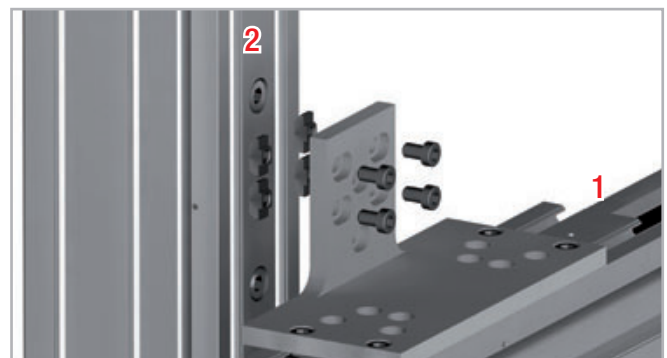

Fig. 94

### Example 2 – System consisting of 1 X-axis and 1 Z-axis

With this configuration, the Z-axis is connected to the slider plate of the X-axis by means of the angle connection plate APC-2.



Fig. 95

**X connection plate APC-3, sizes 40 - 75**

Connection of the two linear axes is achieved by means of the X connection plate APC-3 (see chapter Accessories). To mount the above-mentioned configuration, the following steps should be carried out:

1. Insert the screws from one side of the connection plate into the prepared holes (see fig. 96).
2. Connect the T-nuts by inserting the screws without tightening them and align the nuts in parallel to the slots of the slider plate of unit 1.
3. Place the connection plate against the slider plate and tighten the screws. Ensure that the nuts in the slots were rotated by 90°.
4. Insert the screws from the other side of the connection plate (see fig. 97).
5. Connect the T-nuts by inserting the screws without tightening them and align the nuts in parallel to the slots of the slider plate of unit 2.
6. Place the connection plate against the slider plate and tighten the screws. Ensure that the nuts in the slots were rotated by 90°.

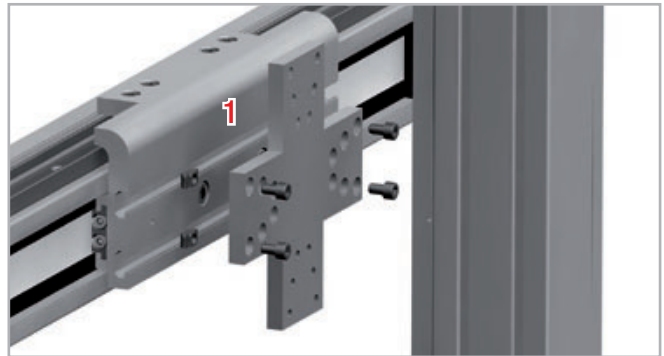

Fig. 96

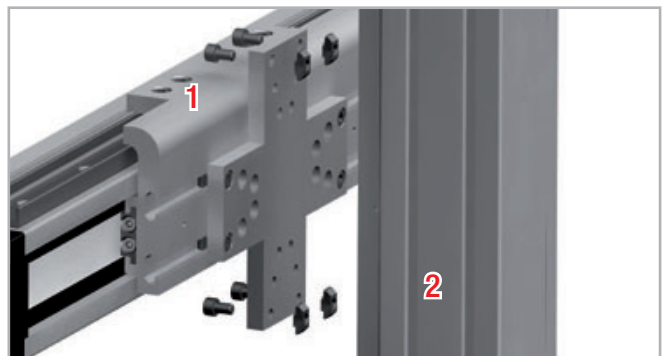

Fig. 97

**Example 3 – System consisting of 2 X-axes, 1 Y-axis and 1 Z-axis**

Connect four linear units to create a 3-axis gantry. The vertical axis is arranged to be self-supporting on the central unit. To do so, connect the two slider plates to each other, using the X connection plate APC-3.

The connection of the two parallel axes to the central unit is attained by means of the T-connection plate APC-1.

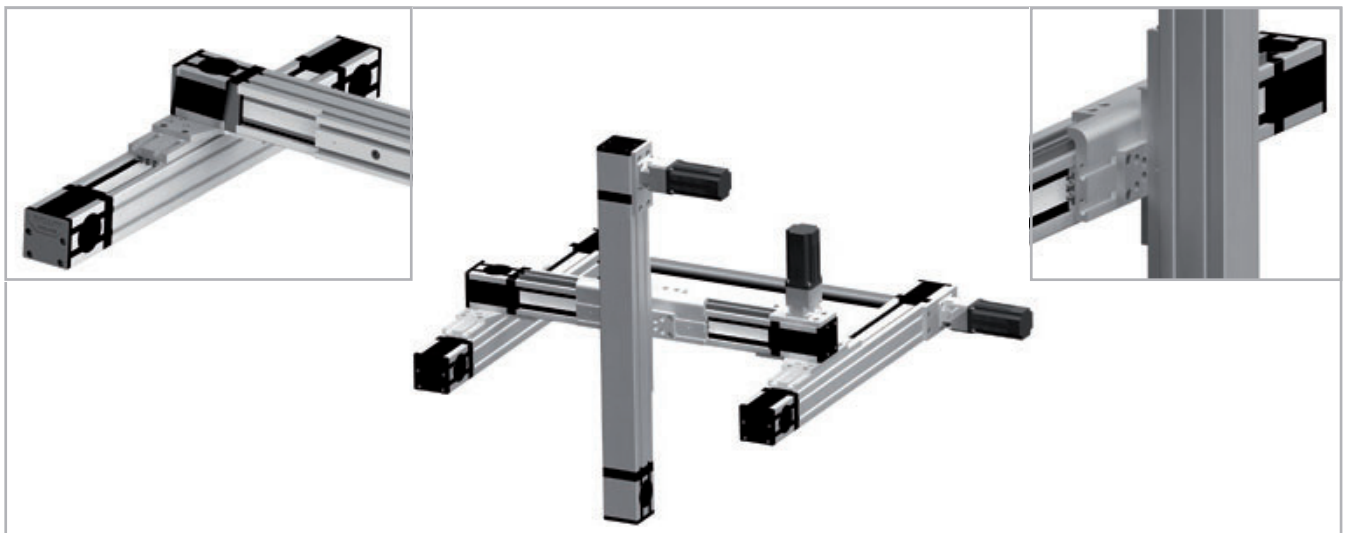

Fig. 98

### Fixing clamp APF-2, sizes 40 - 75

Connection of two linear axes is achieved by means of the fixing clamps APF-2 (see chapter Accessories). To mount the above-mentioned configuration, the following steps should be carried out:

1. Insert the fastening screws into the clamp and, if necessary, place a spacer\* between the clamp and the slider plate.  
\*(Any spacer that is to be used must be manufactured on site)
2. Connect the T-nuts by inserting the screws without tightening them and align the nuts in parallel to the slots of the slider plates.
3. Insert the projecting part of the clamp into the lower slot of the aluminum profile of unit 1.
4. Position the clamp lengthwise according to the desired position of the slider plate of unit 2.

5. Tighten the fastening screws. Ensure that the nuts in the slots were rotated by 90°.

6. Repeat this operation for the required number of fixing clamps.

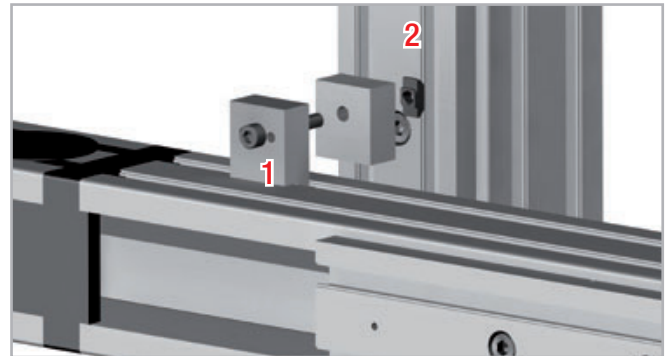

Fig. 99

### Example 4 – System consisting of 1 Y-axis and 2 Z-axes

The connection of the Y-axis to the parallel slider plates is attained via the fixing clamps APF-2.

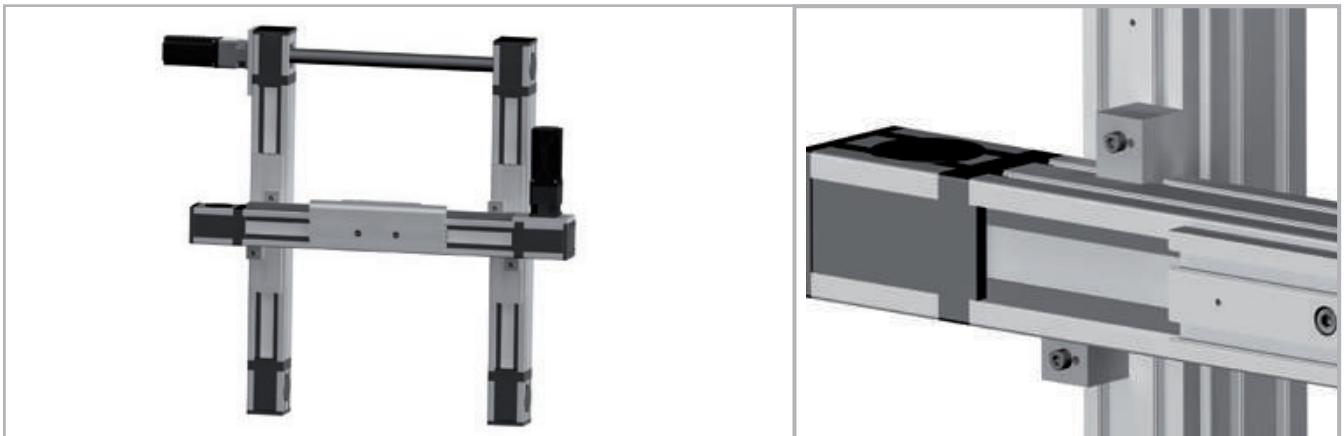

Fig. 100