



克普典科技股份有限公司
Captain Science Corporation

www.capind.com.tw

聯絡方式

citb@ms11.hinet.net

Line ID : @vsh6593b



北區

地址：10057台北市中正區信義路二段61號2樓

電話：(02) 2351-7107 轉 16 或 1

傳真：(02) 2396-4950

中、南區

地址：台中市神岡區中山路667巷26弄18號

電話：(04) 2561-0236 轉 11 或 18

傳真：(04) 2561-0010

R-SMART series**> R-SMART series description**

Fig. 20

R-SMART

The R-SMART series linear units are particularly suitable for: heavy loads, pulling and pushing very heavy weights, demanding work cycles, possible cantilever or gantry mounting, and operation in industrial automated lines.

The extruded and anodized aluminum self-supporting structure with a rectangular section is available in three sizes ranging from 120 to 220 mm. Transmission is achieved with a polyurethane steel reinforced driving belt. Also featured is a dual rail system with four or more recirculating ball bearing runner blocks. Multiple sliders are available to further improve load capacity.

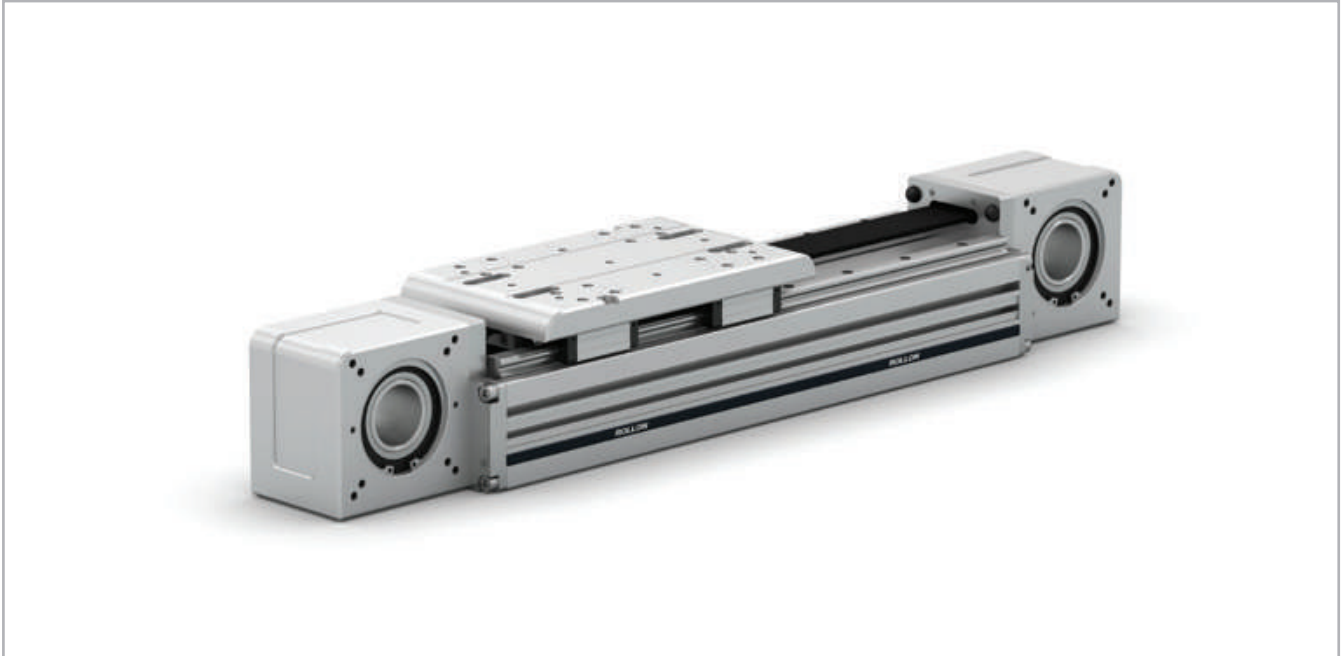
These units are best used in applications requiring very heavy loads in extremely confined spaces, and where machines cannot be stopped to carry out ordinary system maintenance.

> The components

Extruded bodies

The anodized aluminum extrusions used for the bodies of the R-SMART series linear units are designed and manufactured by industry experts to optimize weight while maintaining mechanical strength. (see physical-chemical characteristics below). The dimensional tolerances comply with EN 755-9 standard.

Driving belt

The Rollon SMART series linear units use steel reinforced polyurethane drive belts with AT pitch. This belt is ideal due to its high load transmission characteristics, compact size, and low noise. Used in conjunction with a backlash-free pulley, smooth alternating motion can be achieved.

Optimization of the maximum belt width/body dimension ratio enables the following performance characteristics to be achieved:

- High speed
- Low noise
- Low wear

Carriage

The carriage of the Rollon SMART series linear units is made entirely of machined anodized aluminum. The dimensions vary depending on the type. Rollon offers multiple carriages to accommodate a vast array of applications.

General data about aluminum used: AL 6060

Chemical composition [%]

Al	Mg	Si	Fe	Mn	Zn	Cu	Impurities
Remaining	0.35-0.60	0.30-0.60	0.30	0.10	0.10	0.10	0.05-0.15

Tab. 39

Physical characteristics

Density	Coeff. of elasticity	Coeff. of thermal expansion (20°-100°C)	Thermal conductivity (20°C)	Specific heat (0°-100°C)	Resistivity	Melting point
$\frac{\text{kg}}{\text{dm}^3}$	$\frac{\text{kN}}{\text{mm}^2}$	$\frac{10^{-6}}{\text{K}}$	$\frac{\text{W}}{\text{m} \cdot \text{K}}$	$\frac{\text{J}}{\text{kg} \cdot \text{K}}$	$\Omega \cdot \text{m} \cdot 10^{-9}$	°C
2.7	70	23.8	200	880-900	33	600-655

Tab. 40

Mechanical characteristics

Rm	Rp (02)	A	HB
$\frac{\text{N}}{\text{mm}^2}$	$\frac{\text{N}}{\text{mm}^2}$	%	—
250	200	10	75

Tab. 41

> The linear motion system

The linear motion system has been designed to meet the load capacity, speed, and maximum acceleration conditions of a wide variety of applications. Rollon SMART series systems feature a linear motion system with ball bearing guides:

Performance characteristics:

- The ball bearing guides with high load capacity are mounted in a dedicated seat on the aluminum body.
- The carriage of the linear unit is assembled on preloaded ball bearing blocks that enables the carriage to withstand loading in the four main directions.
- The ball bearing carriages of the SP versions are also fitted with a retention cage that eliminates "steel-steel" contact between adjacent revolving parts and prevents misalignment.
- The blocks have seals on both sides and, when necessary, an additional scraper can be fitted for very dusty conditions.

The linear motion system described above offers:

- High speed and acceleration
- High load capacity
- High permissible bending moments
- Low friction
- Long life
- Low noise

> The driving heads

The couple of symmetrical heads is designed to allow the highest freedom while sizing the application and mounting the gearbox on the R-SMART series linear actuators. Therefore, it is possible to assembly the gearbox on both the heads, either on the right or the left side, by means of a standard assembly kit. This feature is also useful when the unit is assembled to be part of a multiaxis system.

The assembly kit includes: shrink disk; adapter plate and fixing hardware; and can be ordered with the actuator. Different kits are available to accommodate gearboxes from the major brands on the market. For more information see pag. SS-28.

The same logic is valid when mounting the shaft to connect two units in parallel.

R-SMART section

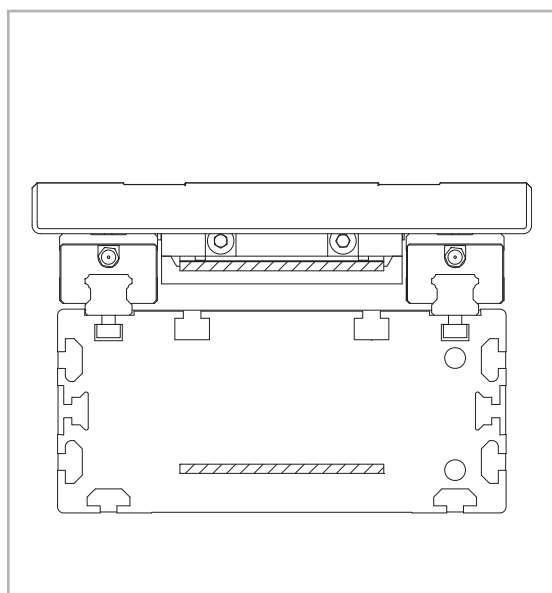
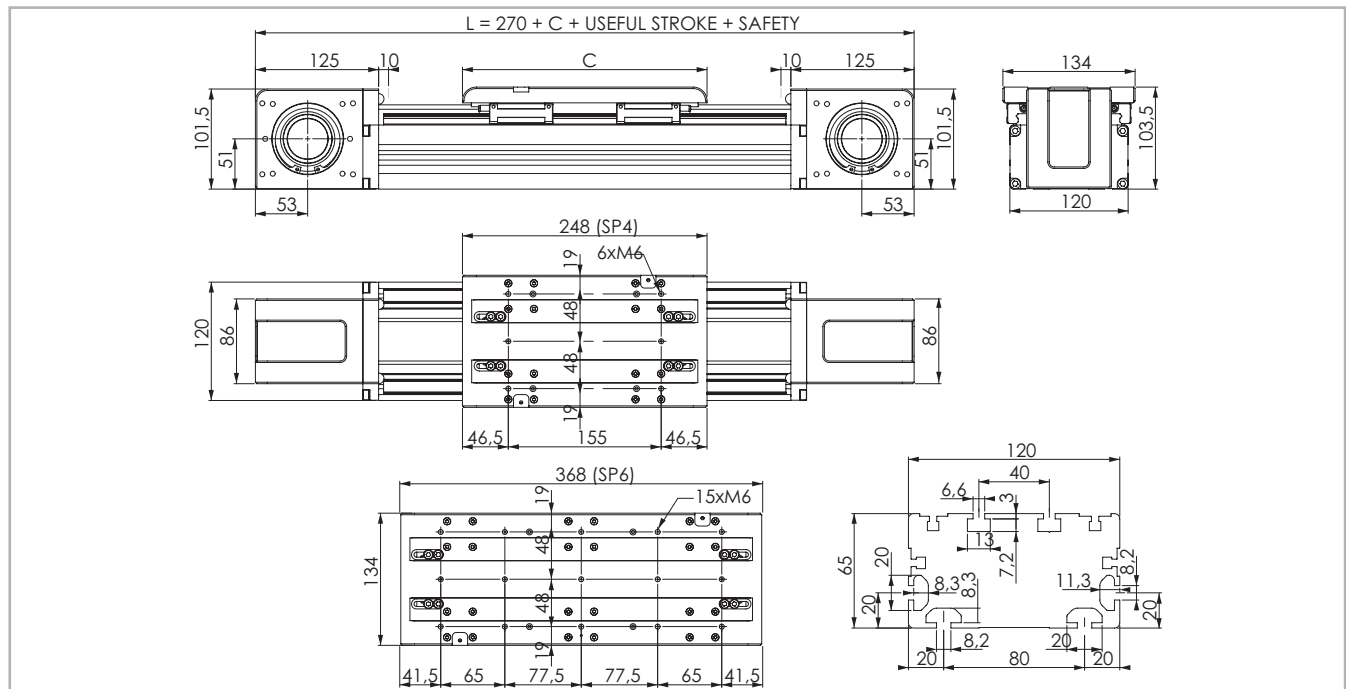

Fig. 21

> R-SMART 120 SP4 - SP6

R-SMART 120 Dimensions



The length of the safety stroke is provided on request according to the customer's specific requirements.

Fig. 22

Technical data

	Type	
	R-SMART 120 SP4	R-SMART 120 SP6
Max. useful stroke length [mm]*1	6050	5930
Max. positioning repeatability [mm]*2	± 0.05	± 0.05
Max. speed [m/s]	4.0	4.0
Max. acceleration [m/s ²]	50	50
Type of belt	40 AT 10	40 AT 10
Type of pulley	Z 21	Z 21
Pulley pitch diameter [mm]	66.84	66.84
Carriage displacement per pulley turn [mm]	210	210
Carriage weight [kg]	2.79	3.94
Zero travel weight [kg]	11.801	13.765
Weight for 100 mm useful stroke [kg]	1.062	1.04
Starting torque [Nm]	1.95	2.3
Moment of inertia of pulleys [g · mm ²]	1.054.300	1.054.300
Rail size [mm]	15	15

*1) It is possible to obtain stroke up to 11.200 (SP4), 11.080 (SP6) by means of special Rollon joints.

*2) Positioning repeatability is dependent on the type of transmission used.

Tab. 42

Load capacity

Type	F _x [N]		F _y [N]		F _z [N]	M _x [Nm]	M _y [Nm]	M _z [Nm]
	Stat.	Dyn.	Stat.	Dyn.	Stat.	Stat.	Stat.	Stat.
R-SMART 120 SP4	3154	2090	50800	39440	50800	2337	3277	3277
R-SMART 120 SP6	3154	2090	76200	59160	76200	3505	6248	6248

See verification under static load and lifetime on page SL-2 and SL-3

F_x in the table represents the maximum capacity of the toothed belt. For the application, the limit of transmittable torque of the shrink disk must be considered too (see page SS-28)

Tab. 44

Moments of inertia of the aluminum body

Type	I _x [10 ⁷ mm ⁴]	I _y [10 ⁷ mm ⁴]	I _p [10 ⁷ mm ⁴]
R-SMART 120 SP	0.108	0.367	0.475

Tab. 43

Driving belt

The driving belt is manufactured from a friction resistant polyurethane and with steel cords for high tensile stress resistance.

Type	Type of belt	Belt width [mm]	Weight [kg/m]
R-SMART 120 SP	40 AT 10	40	0.23

Tab. 44

Belt length (mm) = 2 x L - 115 (SP4)

2 x L - 235 (SP6)

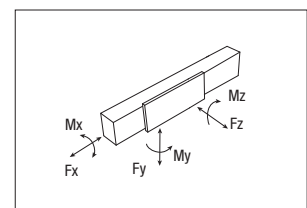

> R-SMART 160 SP4 - SP6

R-SMART 160 Dimensions

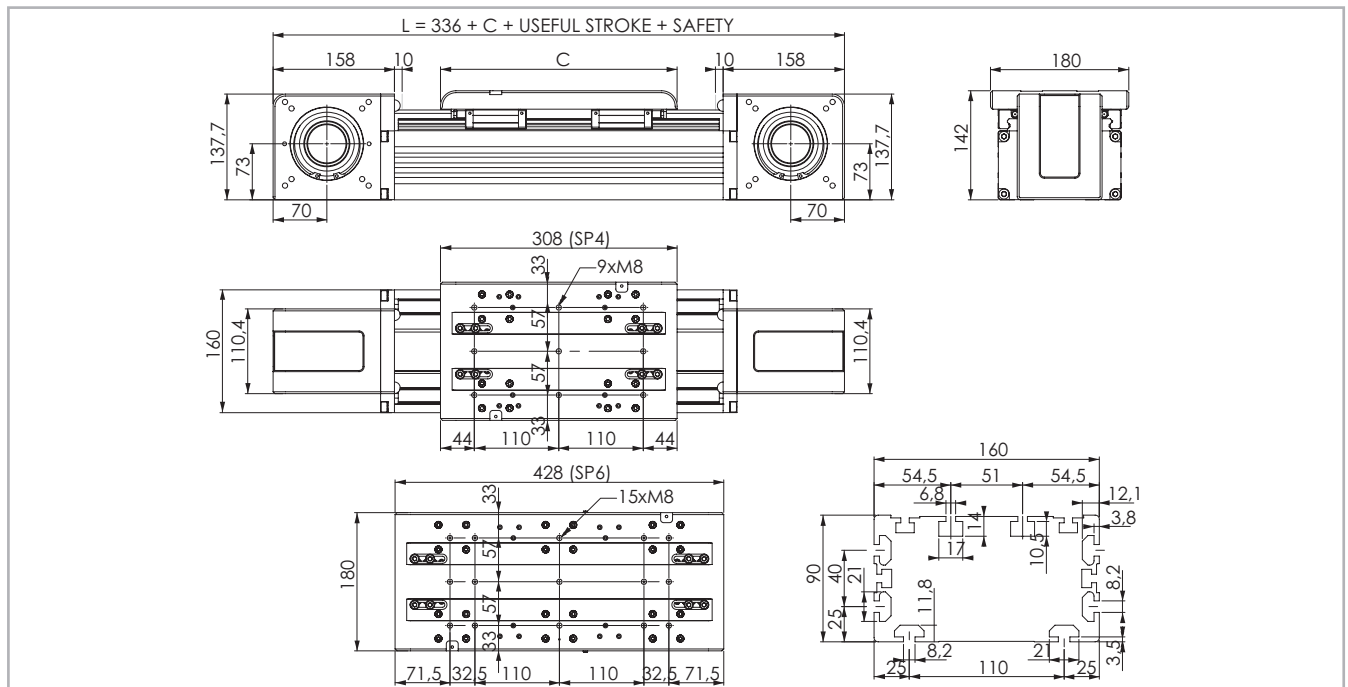

The length of the safety stroke is provided on request according to the customer's specific requirements.

Fig. 23

Technical data

	Type	
	R-SMART 160 SP4	R-SMART 160 SP6
Max. useful stroke length [mm]*1	6000	5880
Max. positioning repeatability [mm]*2	± 0.05	± 0.05
Max. speed [m/s]	4.0	4.0
Max. acceleration [m/s ²]	50	50
Type of belt	50 AT 10	50 AT 10
Type of pulley	Z 27	Z 27
Pulley pitch diameter [mm]	85.94	85.94
Carriage displacement per pulley turn [mm]	270	270
Carriage weight [kg]	6.06	8.6
Zero travel weight [kg]	25.843	30.488
Weight for 100 mm useful stroke [kg]	1.727	1.736
Starting torque [Nm]	3.4	3.95
Moment of inertia of pulleys [g · mm ²]	4.035.390	4.035.390
Rail size [mm]	20	20

*1) It is possible to obtain stroke up to 11.200 (SP4), 11.080 (SP6) by means of special Rollon joints

*2) The positioning repeatability depends upon the type of transmission used

Tab. 46

Load capacity

Type	F _x [N]		F _y [N]		F _z [N]	M _x [Nm]	M _y [Nm]	M _z [Nm]
	Stat.	Dyn.	Stat.	Dyn.	Stat.	Stat.	Stat.	Stat.
R-SMART 160 SP4	4980	3390	110800	88800	110800	6426	9086	9086
R-SMART 160 SP6	4980	3390	166200	133200	166200	9640	15457	15457

See verification under static load and lifetime on page SL-2 and SL-3

F_x in the table represents the maximum capacity of the toothed belt. For the application, the limit of transmittable torque of the shrink disk must be considered too (see page SS-28)

Tab. 49

Moments of inertia of the aluminum body

Type	I _x [10 ⁷ mm ⁴]	I _y [10 ⁷ mm ⁴]	I _p [10 ⁷ mm ⁴]
R-SMART 160 SP	0.383	1.313	1.696

Tab. 47

Driving belt

The driving belt is manufactured from a friction resistant polyurethane and with steel cords for high tensile stress resistance.

Type	Type of belt	Belt width [mm]	Weight [kg/m]
R-SMART 160 SP	50 AT 10	50	0.29

Tab. 48

$$\text{Belt length (mm)} = 2 \times L - 150 \text{ (SP4)}$$

$$2 \times L - 270 \text{ (SP6)}$$

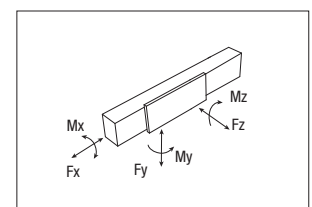

> R-SMART 220 SP4- SP6

R-SMART 220 Dimensions

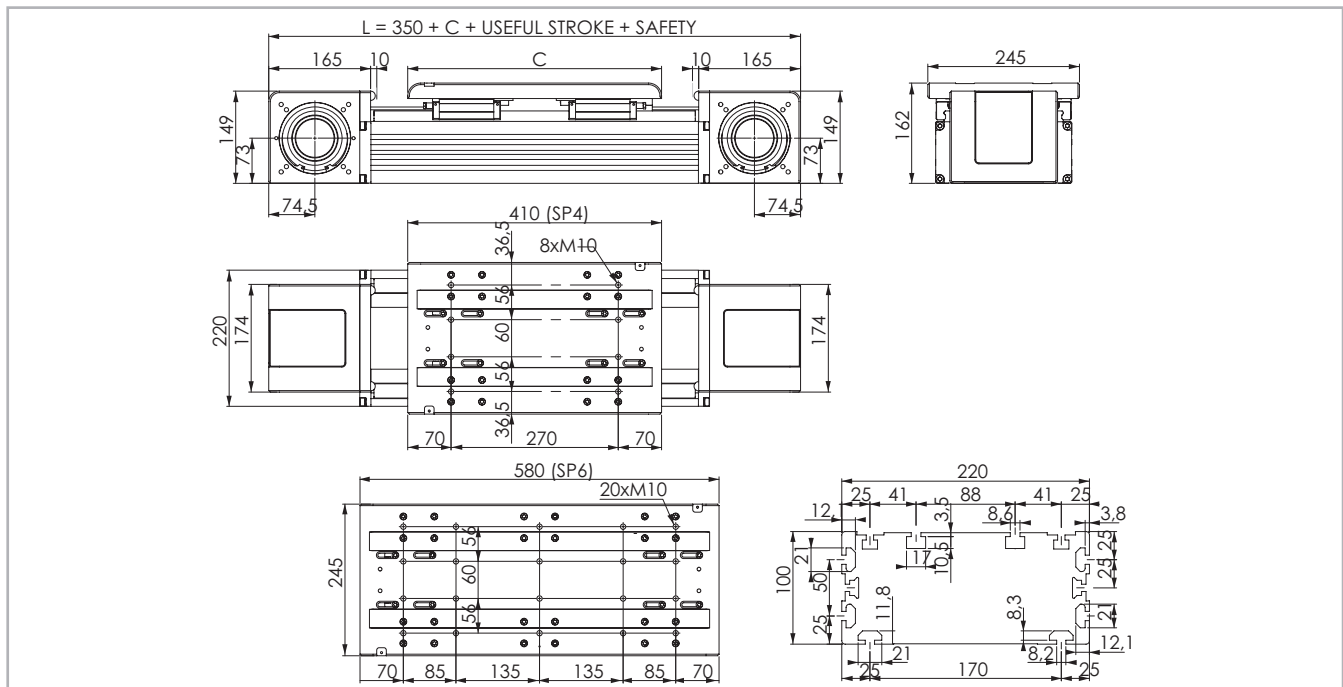

The length of the safety stroke is provided on request according to the customer's specific requirements.

Fig. 24

Technical data

	Type	
	R-SMART 220 SP4	R-SMART 220 SP6
Max. useful stroke length [mm]*1	5900	5730
Max. positioning repeatability [mm]*2	± 0.05	± 0.05
Max. speed [m/s]	4.0	4.0
Max. acceleration [m/s ²]	50	50
Type of belt	100 AT 10	100 AT 10
Type of pulley	Z 32	Z 32
Pulley pitch diameter [mm]	101.86	101.86
Carriage displacement per pulley turn [mm]	320	320
Carriage weight [kg]	12.41	17.37
Zero travel weight [kg]	45.332	54.437
Weight for 100 mm useful stroke [kg]	2.319	2.447
Starting torque [Nm]	4.3	7
Moment of inertia of pulleys [g · mm ²]	12.529.220	12.529.220
Rail size [mm]	25	25

*1) It is possible to obtain stroke up to 11.100 (SP4), 10.930 (SP6) by means of special Rollon joints.

*2) Positioning repeatability is dependent on the type of transmission used.

Tab. 50

Load capacity

Type	F _x [N]		F _y [N]		F _z [N]	M _x [Nm]	M _y [Nm]	M _z [Nm]
	Stat.	Dyn.	Stat.	Dyn.	Stat.	Stat.	Stat.	Stat.
R-SMART 220 SP4	9960	7380	189200	139200	189200	16082	20812	20812
R-SMART 220 SP6	9960	7380	283800	208800	283800	24123	36894	36894

See verification under static load and lifetime on page SL-2 and SL-3

F_x in the table represents the maximum capacity of the toothed belt. For the application, the limit of transmittable torque of the shrink disk must be considered too (see page SS-28)

Tab. 53

Moments of inertia of the aluminum body

Type	I _x [10 ⁷ mm ⁴]	I _y [10 ⁷ mm ⁴]	I _p [10 ⁷ mm ⁴]
R-SMART 220 SP	0.663	3.658	4.321

Tab. 51

Driving belt

The driving belt is manufactured from a friction resistant polyurethane and with steel cords for high tensile stress resistance.

Type	Type of belt	Belt width [mm]	Weight [kg/m]
R-SMART 220 SP	100 AT 10	100	0.58

Tab. 52

Belt length (mm) = 2 x L - 130 (SP4)

2 x L - 300 (SP6)

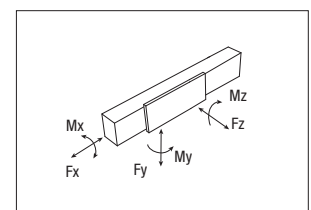

> Lubrication

SP linear units with ball bearing guides

SP Linear units are equipped with self lubricating linear ball guides. The ball bearing carriages of the SP versions are also fitted with a retention cage that eliminates "steel-steel" contact between adjacent revolving parts and prevents misalignment.

This system guarantees a long interval between maintenances: SP version: every 2000 Km or 1 year of use, based on the value reached first. If

a longer service life is required or in case of high dynamic or high loaded applications please contact our offices for further verification.

R-SMART

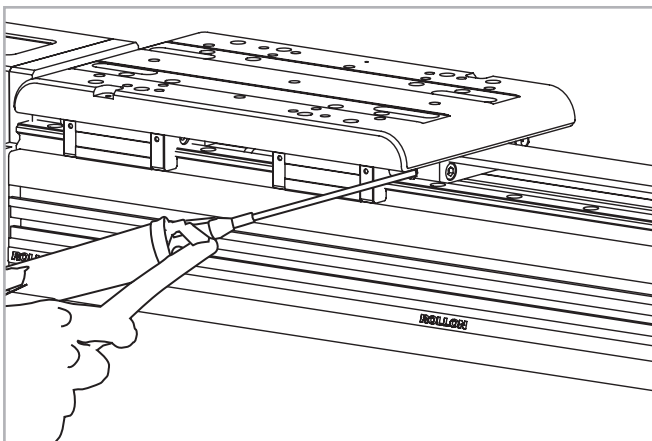

Fig. 25

- Insert the tip of the grease gun into the specific grease blocks.
- Type of lubricant: Lithium soap grease of class NLGI 2.
- For specially stressed applications or hostile environmental conditions, lubrication should be applied out more frequently.
Contact Rollon for further advice

Quantity of lubricant necessary for re-lubrication of each block:

Type	Quantity of Grease [cm ³]
R-SMART 120	0.7
R-SMART 160	1.4
R-SMART 220	2.4

Tab. 54

> Simple shafts

AS type simple shafts

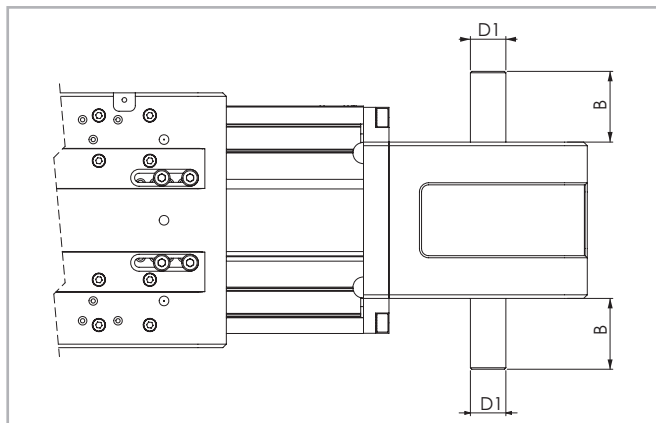

Position of the simple shaft can be to the right or to the left of the drive head.

Fig. 26

This head configuration is obtained by utilizing an assembly kit delivered as a separate accessory item.

Shaft can be installed on the left or right side of the drive head as decided by the customer.

Units (mm)

Applicable to unit	Shaft type	B	D1	AS assembly kit code
R-SMART 120	AS 20	36	20h7	G000828
R-SMART 160	AS 25	50	25h7	G000649
R-SMART 220	AS 25	50	25h7	G002789

Tab. 55

> Hollow shaft

Hollow shaft type AC - Standard supply

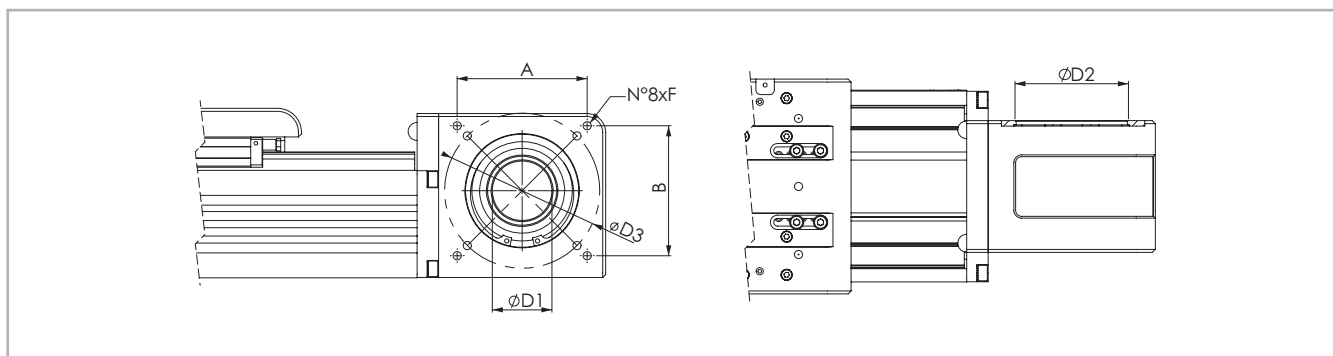

Fig. 27

Units (mm)

Applicable to unit	Shaft type	D1	D2	D3	F	A x B	Drive head code
R-SMART 120	AC 41	41H7	72	100	M6	92x72	2R
R-SMART 160	AC 50	50H7	95	130	M8	109x109	2R
R-SMART 220	AC 60	60H7	115	130	M8	109x109	2R

Tab. 56

An (optional) connection flange is required to fit the standard reduction units selected by Rollon.

For further information contact our offices.

> Accessories

Fixing by brackets

The ball bearing guide linear drive system of Rollon SMART System series linear units enables them to support loads in any direction. They can therefore be installed in any position.

To install the SMART System series units, we recommend use of one of the systems indicated below:

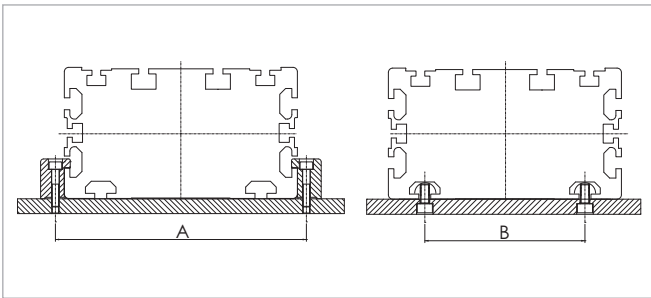

Fig. 28

Units (mm)

	A	B
R-SMART 120	132	80
R-SMART 160	180	110
R-SMART 220	240	170

Tab. 57

Fixing brackets

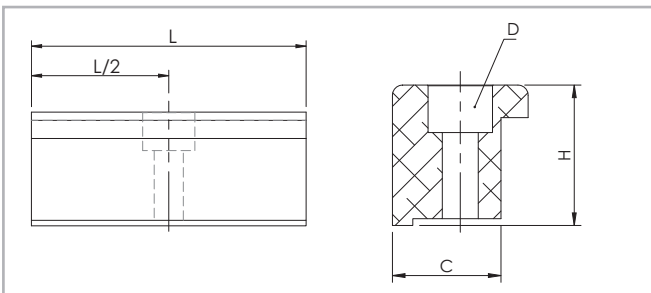

Fig. 29

Dimensions (mm)

	C	H	L	D	Code Rollon
R-SMART 120	16	20.7	50	M5	1000111
R-SMART 160	31	28.5	100	M10	1002377
R-SMART 220	31	28.5	100	M10	1002377

Tab. 58

T-nuts

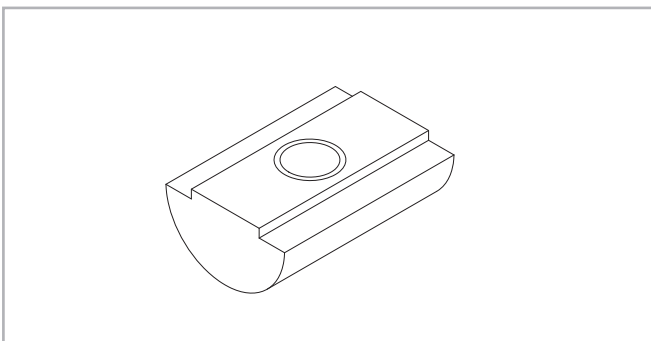

Steel nuts to be used in the slots of the body.

Fig. 30

Units (mm)

	Hole	Length	Code Rollon
R-SMART 120	M6	20	6000437
R-SMART 160	M6	20	6000437
R-SMART 160	M8	20	6001544
R-SMART 220	M6	20	6000437
R-SMART 220	M8	20	6001544

Tab. 59

Proximity

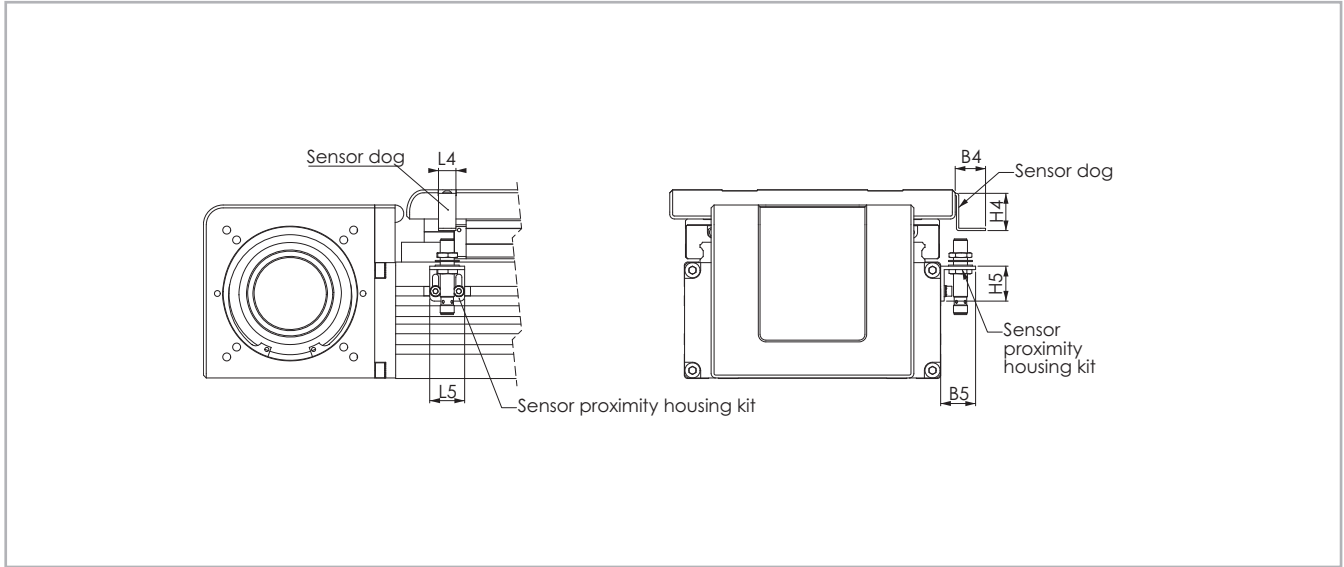

Fig. 31

Sensor proximity housing kit

Aluminum block equipped with T-nuts for fixing

Sensor dog

Iron plate mounted on the carriage used for the proximity operation

Units (mm)

	B4	B5	L4	L5	H4	H5	For proximity	Sensor dog	Sensor proximity housing kit
R-SMART 120	26	30	15	30	32	30	Ø 8	G000833	G000844
R-SMART 160	26	30	15	30	32	30	Ø 8	G000833	G000838
R-SMART 220	26	30	15	30	32	30	Ø 8	G000833	G000838

Tab. 60

Assembly kits

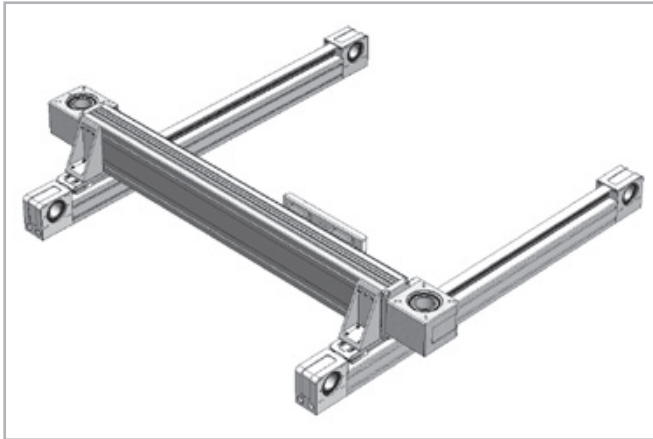







Fig. 32



Fig. 33

For the direct assembly of R-SMART linear units on other types of actuators Rollon offers dedicated assembly kits. The table below shows the allowed combinations as well as the assembly kit codes.

	Kit	Code	X No rail at each end (mm)
	R-SMART 120 on E-SMART 50	G000899*	60
	R-SMART 120 on E-SMART 80	G000863*	90
	R-SMART 160 on E-SMART 80	G000902*	90
	R-SMART 160 on E-SMART 100	G000903*	110
	R-SMART 220 on E-SMART 100	G001207	110

* Additional fixing holes are requested on the E-SMART plate.

Tab. 61

Adapter flange for gearbox assembly

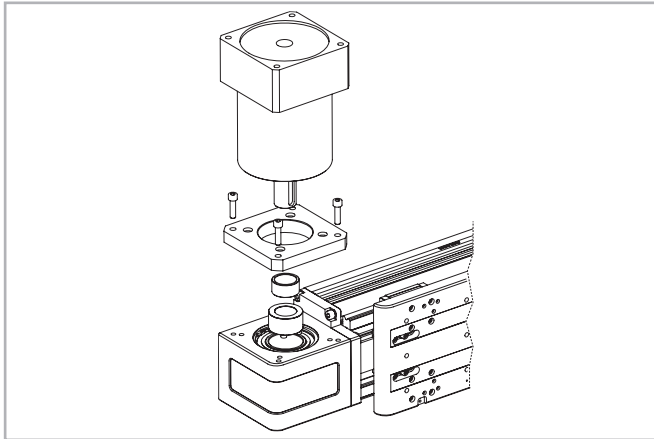

Fig. 34

Assembly kit includes: shrink disc; adapter plate; fixing hardware

Single shrink disc



Fig. 35

Codes on the table below refer to a shrink disc ordered as single element.

Unit type	Gearbox type (not included)	Kit Code
R-SMART 120	P3	G000824
	MP080	G000826
	LC90; MPV01; NP025S; PE4	G000827
	MP105	G000830
	PE3; NP015S; LC070	G001078
	SP060; PLN070	G000829
	SP070; PLN090	G000859
	SW040	G000866
R-SMART 160	MP130	G000482
	LC120; MPV02; NP035S; PE5	G000483
	LC090; NP025S; PE4	G000525
	MP105	G000527
	SP075; PLN090	G000526
	SW050	G000717
R-SMART 220	MP130	G002785
	MP105	G002786
	LP120; LC120; PE5	G002787
	SP100	G002788

Tab. 62

For other gearbox type ask Rollon

Unit type	Hollow shaft [mm]	Shrink disc dxD [mm]	Transmittable torque* [Nm]	Shrink disc code
R-SMART 120	41	19x41	150	6005734
		22x41	174	6005735
		25x41	198	6005736
R-SMART 160	50	22x50	286	6005730
		25x50	324	6005731
		32x50	415	6005732
R-SMART 220	60	22x60	343	6005298
		25x60	389	6005299
		32x60	498	6005300

* Transmittable torque in the table represents the maximum capacity of the shrink disc. Tab. 63
For the application, the limit of F_r must be considered too.

Ordering key

> Identification codes for the R-SMART linear unit

D	12 12=120 16=160 22=220	2R	02000	4R	
					Type (120-160-220) 4R=SP4 6R=SP6
					L=total length of the unit
					Drive head code <i>see pg. SS-24</i>
					Linear unit type <i>see from pg. SS-20 to pg. SS-22</i>
					Linear unit series R-SMART <i>see pg. SS-17</i>

In order to create identification codes for Actuator Line, you can visit: <http://configureactuator.rollon.com>



Left / right orientation

