



克普典科技股份有限公司
Captain Science Corporation

www.capind.com.tw

聯絡方式

citb@ms11.hinet.net

Line ID : @vsh6593b



北區

地址：10057台北市中正區信義路二段61號2樓

電話：(02) 2351-7107 轉 16 或 1

傳真：(02) 2396-4950

中、南區

地址：台中市神岡區中山路667巷26弄18號

電話：(04) 2561-0236 轉 11 或 18

傳真：(04) 2561-0010

ELM series



> ELM series description



Fig. 1

ELM

This is Rollon's highly versatile, premier line of completely enclosed belt driven linear actuators.

The ELM series linear units are available in four sizes: 50 - 65 - 80-110 mm. They have a self-supporting structure with a robust profile of extruded and anodized aluminum. The thrust force is transmitted by a steel reinforced, polyurethane belt. The moving carriage is guided and supported by a linear guide system.

A polyurethane sealing strip ensures complete protection of the belt drive and linear guide system against dust, dirt and other contaminants. It avoids the fragility of other sealing systems such as stainless steel strips.

The components used for linear motion and accessories promote a "maintenance-free" system. The pulleys, bearings and drive shafts are among the most robust in the industry. The ELM is the best product for applications in very aggressive working environments that also require high speed duty cycles and position repeatability.

Corrosion resistant version

ELM linear actuators are available with stainless steel elements, for applications in harsh environments and/or subject to frequent washes.

They are constructed using extruded anodized 6060 and 6082 Anti-Corrosive Aluminum, which houses bearings, linear rails, nuts and bolts and components made of stainless steel preventing or delaying corrosion caused by humidity experienced in the environments where the linear units are used.

Special no-deposit surface treatments are combined with a food grade lubrication system to allow use in highly sensitive applications, such as the food and pharmaceutical industries where product contamination is prohibited.

- Internal stainless steel elements
- Anodized 6060 and 6082 Anti-Corrosive Aluminum Profile
- AISI 440 stainless steel linear rails
- Lubricated with organic food grade vegetable oils

> The components

Extruded profile

The anodized 6060 aluminum alloy extrusion used for the profile of ELM series linear units are designed and manufactured by industry experts to optimize weight while maintaining mechanical strength. (see physical-chemical characteristics below). The dimensional tolerances comply with EN 755-9 standard.

Driving belt

ELM series linear units use steel reinforced polyurethane drive belts with AT pitch. This belt is ideal due to its high load transmission characteristics, compact size and low noise. Used in conjunction with a backlash-free pulley, smooth alternating motion can be achieved. Optimization of the maximum belt width/body dimension ratio enables the following performance characteristics to be achieved:

- High speed
- Low noise
- Low wear

Carriage

The carriage of the ELM series linear units are made of anodized aluminum. Each carriage has mounting holes fitted with stainless steel thread inserts. Rollon offers multiple carriages to accommodate a vast array of applications. The unique design of the carriage allows for the sealing strip to pass through it, as well as house brush seals to remove contaminants from the sealing strip.

Sealing strip

ELM series linear units are equipped with a polyurethane sealing strip to protect all of the internal components from dust, contaminants, and other foreign objects. The sealing strip runs the length of the body and is kept in position by micro-bearings located inside the carriage. This minimizes resistance as the strip passes through the carriage while providing maximum protection.

General data about aluminum used: AL 6060

Chemical composition [%]

Al	Mg	Si	Fe	Mn	Zn	Cu	Impurities
Remaining	0.35-0.60	0.30-0.60	0.30	0.10	0.10	0.10	0.05-0.15

Tab. 1

Physical characteristics

Density	Coeff. of elasticity	Coeff. of thermal expansion (20°-100°C)	Thermal conductivity (20°C)	Specific heat (0°-100°C)	Resistivity	Melting point
$\frac{\text{kg}}{\text{dm}^3}$	$\frac{\text{kN}}{\text{mm}^2}$	$\frac{10^{-6}}{\text{K}}$	$\frac{\text{W}}{\text{m} \cdot \text{K}}$	$\frac{\text{J}}{\text{kg} \cdot \text{K}}$	$\Omega \cdot \text{m} \cdot 10^{-9}$	°C
2.7	69	23	200	880-900	33	600-655

Tab. 2

Mechanical characteristics

Rm	Rp (02)	A	HB
$\frac{\text{N}}{\text{mm}^2}$	$\frac{\text{N}}{\text{mm}^2}$	%	—
205	165	10	60-80

Tab. 3

> The linear motion system

The linear motion system has been designed to meet the load capacity, speed, and maximum acceleration conditions of a wide variety of applications.

ELM with ball bearing guides

- A ball bearing guide with high load capacity is mounted in a dedicated seat inside the body.
- The carriage is assembled on two pre-loaded ball bearing blocks.
- The two ball bearing blocks enable the carriage to withstand loading in the four main directions.
- The two blocks have seals on both sides and, if necessary, an additional scraper can be fitted for very dusty conditions.
- The ball bearing carriages are also fitted with a retention cage that eliminates "steel-steel" contact between adjacent revolving parts and prevents misalignment.
- Lubrication reservoirs (pockets) installed on the front of the ball bearing blocks supply the right amount of grease, thus promoting long maintenance interval.

The linear motion system described above offers:

- High speed and acceleration
- High load capacity
- High permissible bending moments
- Low friction
- Long life
- Maintenance free (depending on applications)
- Low noise

ELM section

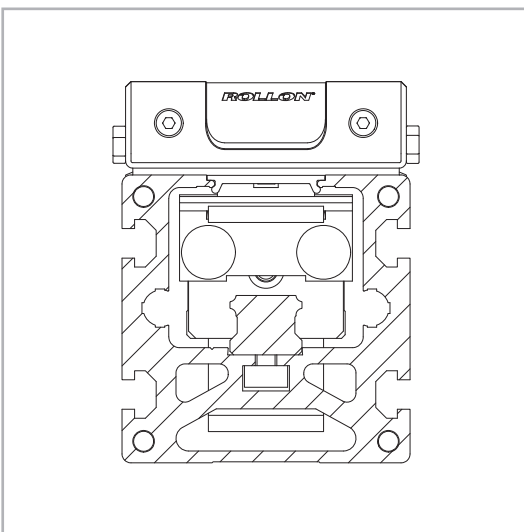

Fig. 2

> The new driving head

The new driving head is designed to allow high freedom while sizing the application and mounting the gearbox on the ELM series linear actuators. With the new head, it is possible to assembly the gearbox on either the right or the left side of the actuator by means of a standard assembly kit.

The assembly kit includes: shrink disk; adapter plate and fixing hardware; and can be ordered with the actuator. Different kits are available to accommodate gearboxes from the major brands on the market. For more information see pag. PLS-14.

The same logic is valid when mounting the shaft to connect two units in parallel.

> ELM 50

ELM 50 Dimensions

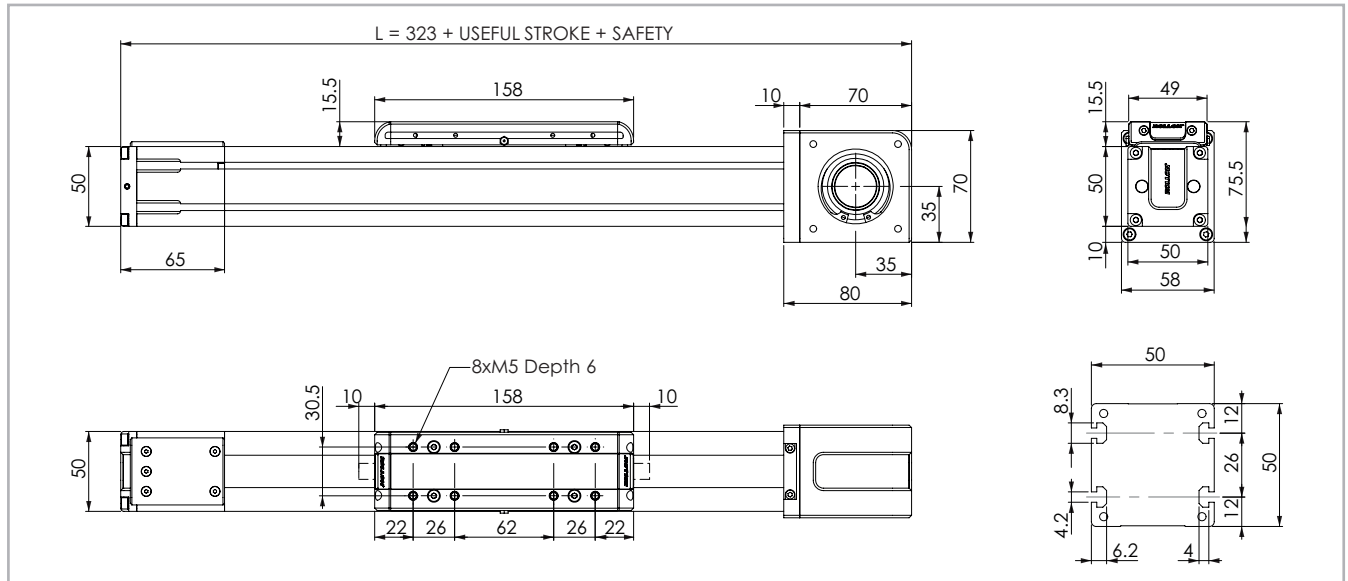

The length of the safety stroke is provided on request according to the customer's specific requirements.

Fig. 3

Technical data

	Type
	ELM 50
Max. useful stroke length [mm]*1	6130
Max. positioning repeatability [mm]*2	± 0.05
Max. speed [m/s]	4.0
Max. acceleration [m/s ²]	50
Type of belt	22 AT 5
Type of pulley	Z 23
Pulley pitch diameter [mm]	36.61
Carriage displacement per pulley turn [mm]	115
Carriage weight [kg]	0.48
Zero travel weight [kg]	2.278
Weight for 100 mm useful stroke [kg]	0.416
Starting torque [Nm]	0.4
Moment of inertia of pulleys [g·mm ²]	30228
Rail size [mm]	12 mini

*1) It is possible to obtain strokes up to 9000 mm by means of special Rollon joints

*2) Positioning repeatability is dependent on the type of transmission used

Tab. 4

Load capacity

Type	F _x [N]		F _y [N]		F _z [N]	M _x [Nm]	M _y [Nm]	M _z [Nm]
	Stat.	Dyn.	Stat.	Dyn.	Stat.	Stat.	Stat.	Stat.
ELM 50	809	508	7060	6350	7060	46.2	233	233

See verification under static load and lifetime on page SL-2 and SL-3

F_x in the table represents the maximum capacity of the toothed belt. For the application, the limit of transmittable torque of the shrink disk must be considered too (see page PLS-14).

Tab. 7

Moments of inertia of the aluminum body

Type	I _x [10 ⁷ mm ⁴]	I _y [10 ⁷ mm ⁴]	I _p [10 ⁷ mm ⁴]
ELM 50	0.025	0.031	0.056

Tab. 5

Driving belt

The driving belt is manufactured from a friction resistant polyurethane and with steel cords for high tensile stress resistance.

Type	Type of belt	Belt width [mm]	Weight [kg/m]
ELM 50	22 AT 5	22	0.072

Tab. 6

Belt length (mm) = 2 x L - 125

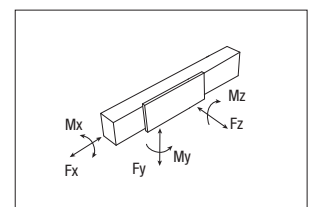

> ELM 65

ELM 65 Dimensions

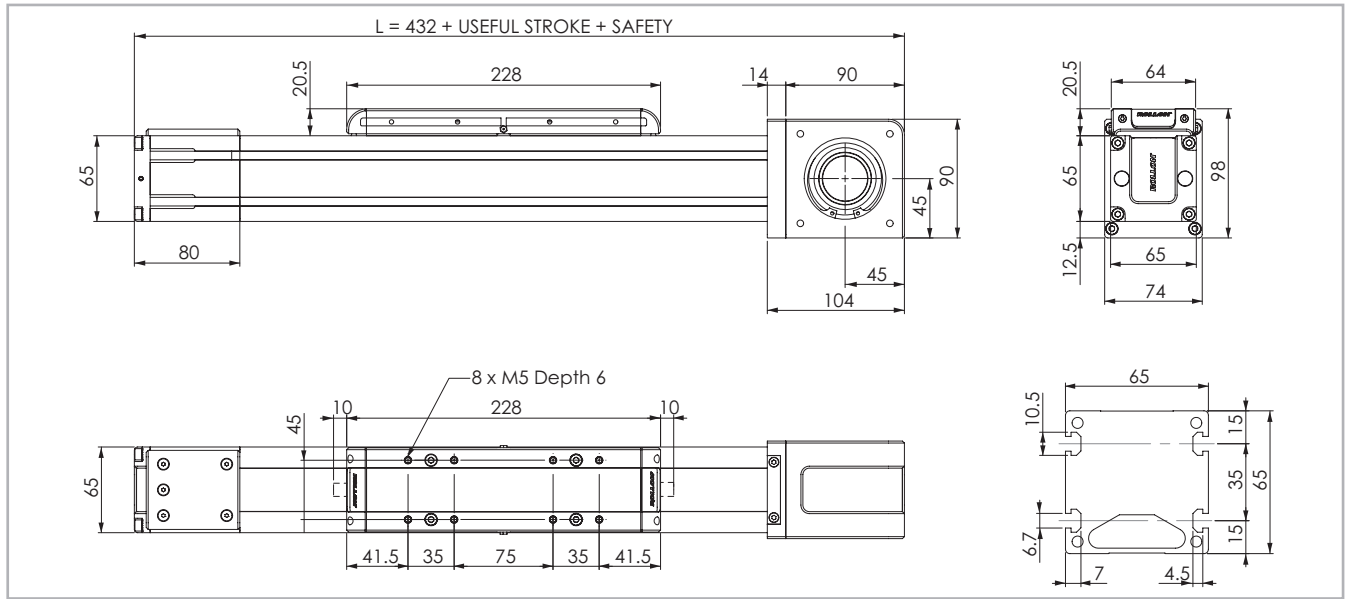

The length of the safety stroke is provided on request according to the customer's specific requirements.

Fig. 4

Technical data

	Type
	ELM 65
Max. useful stroke length [mm]*1	6060
Max. positioning repeatability [mm]*2	± 0.05
Max. speed [m/s]	5.0
Max. acceleration [m/s ²]	50
Type of belt	32 AT 5
Type of pulley	Z 32
Pulley pitch diameter [mm]	50.93
Carriage displacement per pulley turn [mm]	160
Carriage weight [kg]	1.438
Zero travel weight [kg]	5.411
Weight for 100 mm useful stroke [kg]	0.589
Starting torque [Nm]	1.5
Moment of inertia of pulleys [g·mm ²]	185496
Rail size [mm]	15

*1) It is possible to obtain strokes up to 11000 mm by means of special Rollon joints

*2) Positioning repeatability is dependent on the type of transmission used

Tab. 8

Moments of inertia of the aluminum body

Type	I_x [10 ⁷ mm ⁴]	I_y [10 ⁷ mm ⁴]	I_D [10 ⁷ mm ⁴]
ELM 65	0.060	0.086	0.146

Tab. 9

Driving belt

The driving belt is manufactured from a friction resistant polyurethane and with steel cords for high tensile stress resistance.

Type	Type of belt	Belt width [mm]	Weight [kg/m]
ELM 65	32 AT 5	32	0.105

Tab. 10

Belt length (mm) = 2 x L - 175

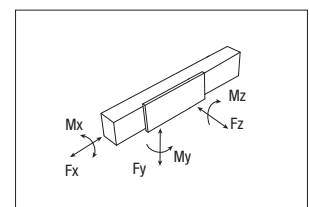

Load capacity

Type	F_x [N]		F_y [N]		F_z [N]	M_x [Nm]	M_y [Nm]	M_z [Nm]
	Stat.	Dyn.	Stat.	Dyn.	Stat.	Stat.	Stat.	Stat.
ELM 65	1344	883	48400	22541	48400	320	1376	1376

See verification under static load and lifetime on page SL-2 and SL-3

F_x in the table represents the maximum capacity of the toothed belt. For the application, the limit of transmittable torque of the shrink disk must be considered too (see page PLS-14).

Tab. 11

> ELM 80

ELM 80 Dimensions

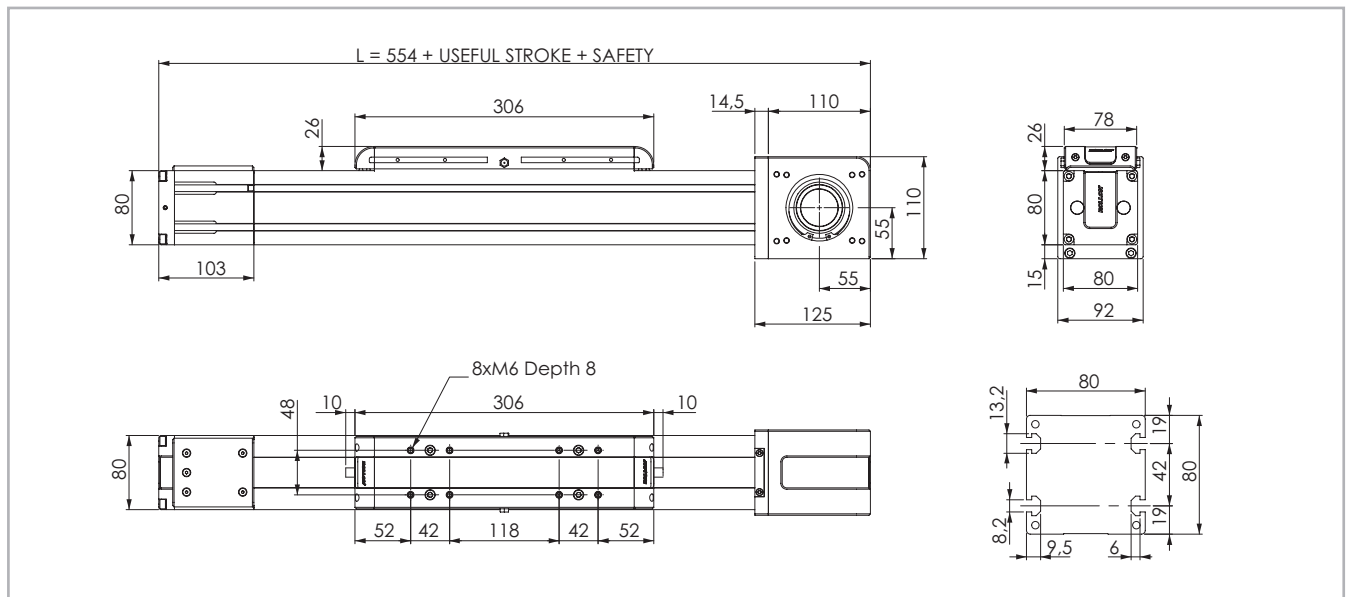

The length of the safety stroke is provided on request according to the customer's specific requirements.

Fig. 5

Technical data

	Type
	ELM 80
Max. useful stroke length [mm]*1	5980
Max. positioning repeatability [mm]*2	± 0.05
Max. speed [m/s]	5.0
Max. acceleration [m/s ²]	50
Type of belt	32 AT 10
Type of pulley	Z 19
Pulley pitch diameter [mm]	60.48
Carriage displacement per pulley turn [mm]	190
Carriage weight [kg]	3.12
Zero travel weight [kg]	10.761
Weight for 100 mm useful stroke [kg]	1.02
Starting torque [Nm]	2.2
Moment of inertia of pulleys [g·mm ²]	400064
Rail size [mm]	20

*1) It is possible to obtain strokes up to 11000 mm by means of special Rollon joints

*2) Positioning repeatability is dependent on the type of transmission used

Tab. 12

Load capacity

Type	F _x [N]		F _y [N]		F _z [N]	M _x [Nm]	M _y [Nm]	M _z [Nm]
	Stat.	Dyn.	Stat.	Dyn.	Stat.	Stat.	Stat.	Stat.
ELM 80	2258	1306	76800	35399	76800	722	5606	5606

See verification under static load and lifetime on page SL-2 and SL-3

F_y in the table represents the maximum capacity of the toothed belt. For the application, the limit of transmittable torque of the shrink disk must be considered too (see page PLS-14).

Tab. 15

Moments of inertia of the aluminum body

Type	I _x [10 ⁷ mm ⁴]	I _y [10 ⁷ mm ⁴]	I _p [10 ⁷ mm ⁴]
ELM 80	0.136	0.195	0.331

Tab. 13

Driving belt

The driving belt is manufactured from a friction resistant polyurethane and with steel cords for high tensile stress resistance.

Type	Type of belt	Belt width [mm]	Weight [kg/m]
ELM 80	32 AT 10	32	0.185

Tab. 14

Belt length (mm) = 2 x L - 230

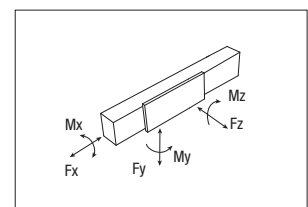

> ELM 110

ELM 110 Dimensions

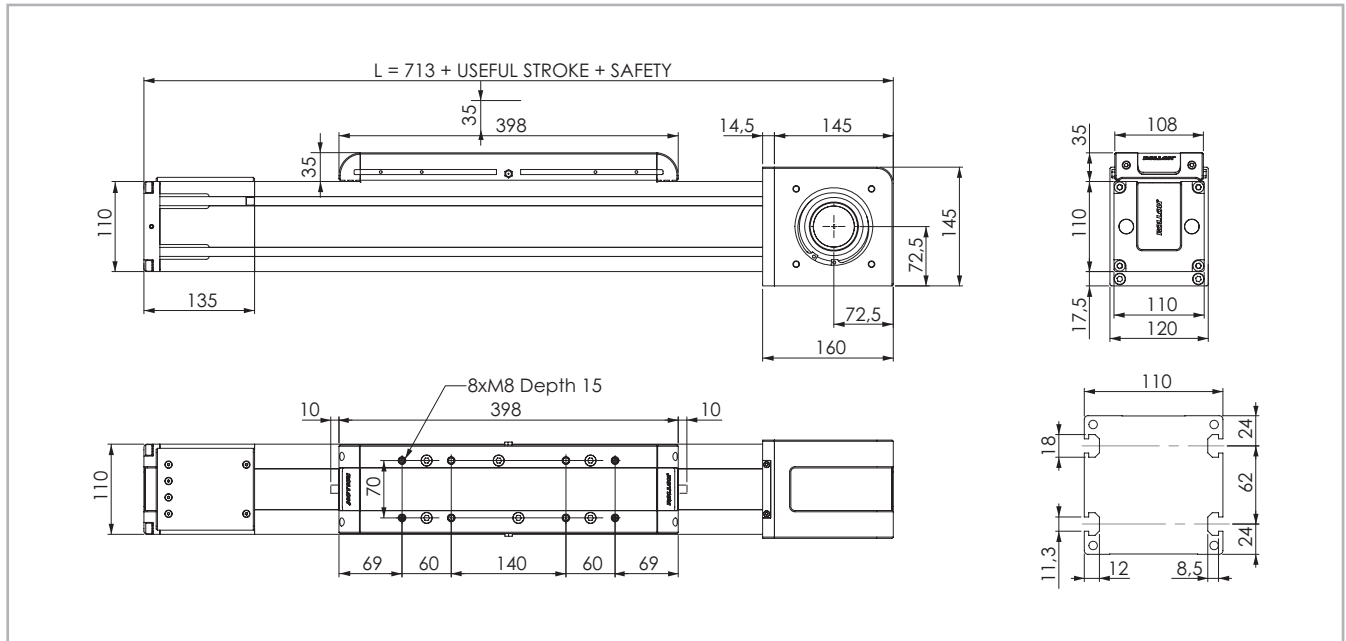

The length of the safety stroke is provided on request according to the customer's specific requirements.

Fig. 6

Technical data

	Type
	ELM 110
Max. useful stroke length [mm]*1	5900
Max. positioning repeatability [mm]*2	± 0.05
Max. speed [m/s]	5.0
Max. acceleration [m/s ²]	50
Type of belt	50 AT 10
Type of pulley	Z 27
Pulley pitch diameter [mm]	85.94
Carriage displacement per pulley turn [mm]	270
Carriage weight [kg]	6.82
Zero travel weight [kg]	23.898
Weight for 100 mm useful stroke [kg]	1.443
Starting torque [Nm]	3.5
Moment of inertia of pulleys [g·mm ²]	2.286·10 ⁶
Rail size [mm]	25

*1) It is possible to obtain strokes up to 11000 mm by means of special Rollon joints

*2) Positioning repeatability is dependent on the type of transmission used

Tab. 16

Load capacity

Type	F _x [N]		F _y [N]		F _z [N]	M _x [Nm]	M _y [Nm]	M _z [Nm]
	Stat.	Dyn.	Stat.	Dyn.	Stat.	Stat.	Stat.	Stat.
ELM 110	4980	3300	129400	58416	129400	1392	11646	11646

See verification under static load and lifetime on page SL-2 and SL-3

F_x in the table represents the maximum capacity of the toothed belt. For the application, the limit of transmittable torque of the shrink disk must be considered too (see page PLS-14).

Tab. 19

Moments of inertia of the aluminum body

Type	I _x [10 ⁷ mm ⁴]	I _y [10 ⁷ mm ⁴]	I _p [10 ⁷ mm ⁴]
ELM 110	0.446	0.609	1.054

Tab. 17

Driving belt

The driving belt is manufactured from a friction resistant polyurethane and with steel cords for high tensile stress resistance.

Type	Type of belt	Belt width [mm]	Weight [kg/m]
ELM 110	50 AT 10	50	0.290

Tab. 18

Belt length (mm) = 2 x L - 280

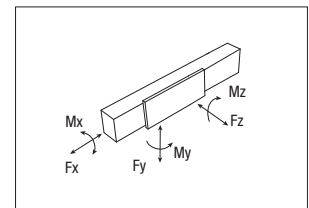

> Lubrication

ELM Linear units are equipped with self lubricating linear ball guides. The ball bearing carriages are also fitted with a retention cage that eliminates "steel-steel" contact between adjacent revolving parts and prevents misalignment of these in the circuits.

Special lubrication reservoirs are mounted on the front plates of the linear blocks which continuously provide the necessary amount of grease to the ball raceways under load. These lubrication reservoirs also considerably reduce the frequency of lubrication of the module. This system guarantees a long interval between maintenances: every 5000 km or 1 year of use, based on the value reached first. If a longer service life is required or in case of high dynamic or high loaded applications please contact our offices for further verification.

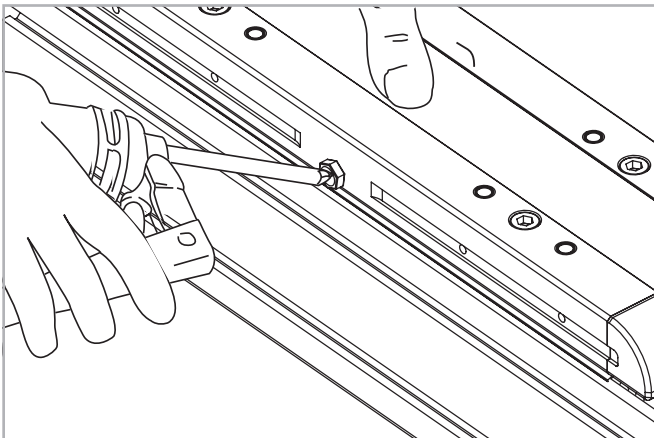

Fig. 7

- Insert the tip of the grease gun in the specific grease blocks.
- For lubrication of linear units use lithium soap grease NLGI 2.
- For specially stressed applications or difficult environmental conditions, lubrication should be carried out more frequently. Refer to Rollon for further advice.

Quantity of lubricant necessary for re-lubrication:

Type	Unit: [cm ³]
ELM 50	1
ELM 65	1.4
ELM 80	2.8
ELM 110	4.8

Tab. 20

> Simple shaft version

Simple shaft type AS

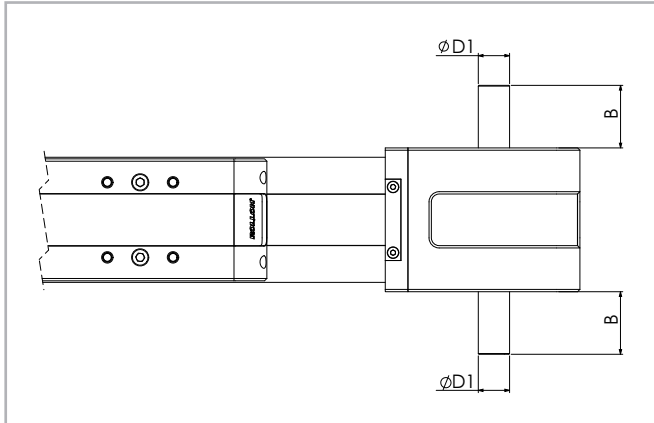

Fig. 8

Unit	Shaft type	B	D1
ELM 50	AS 12	25	12h7
ELM 65	AS 15	35	15h7
ELM 80	AS 20	40	20h7
ELM 110	AS 25	50	25h7

Tab. 21

Position of the simple shaft can be to the right, left, or both sides of the drive head.

Unit	Shaft type	B	D1	AS assembly kit code
ELM 50	AS 12	25	12h7	G002697
ELM 65	AS 15	35	15h7	G000851
ELM 80	AS 20	40	20h7	G002696
ELM 110	AS 25	50	25h7	G000649

Tab. 22

Simple shaft type AE 10 for encoder assembly + AS

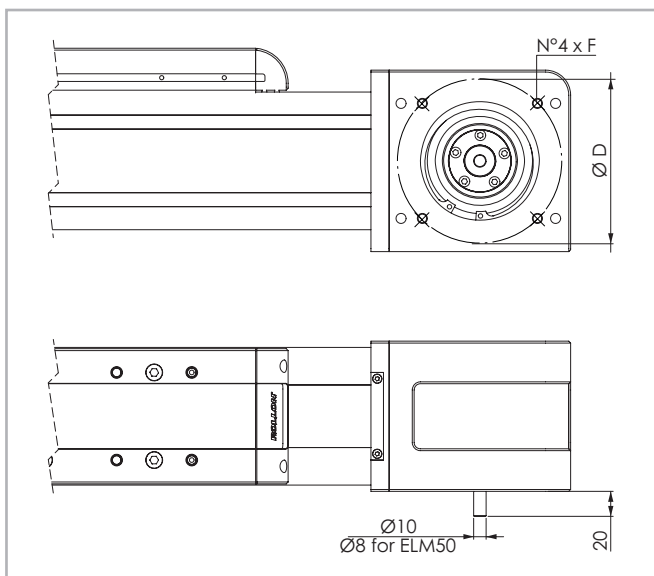

Fig. 9

Unit	Code kit AE	$\varnothing D$	F
ELM 50	G002744	75	M5
ELM 65	G002592	96	M6
ELM 80	G002745	100	M6
ELM 110	G002370	130	M8

Tab. 23

Position of the simple shafts for encoder assembly to the right or to the left on the drive head.

Air Hole

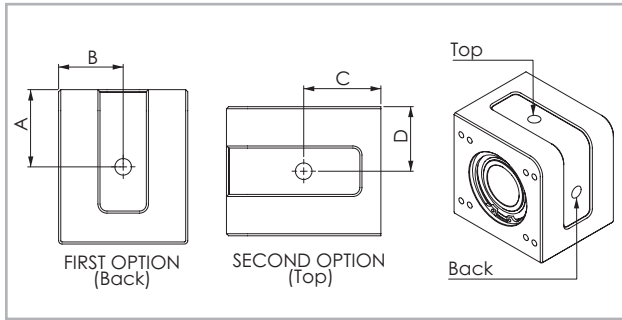

Fig. 10

Unit	First		Second	
	A	B	C	D
ELM 50	35	29	35	29
ELM 65	45	37	45	37
ELM 80	55	46	55	46
ELM 110	72.5	60	72.5	60

Tab. 24

> **Hollow shafts**

Hollow shaft

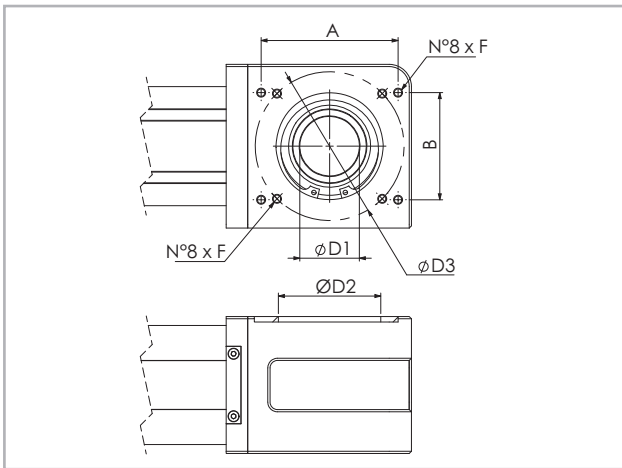

Fig. 11

Dimensions (mm)

Applicable to unit	Shaft type	D1	D2	D3	A	B	F
ELM 50	FP 26	26 H7	47	75	-	-	M5
ELM 65	FP 34	34 H7	62	96	-	-	M6
ELM 80	FP 41	41 H7	72	100	92	72	M6
ELM 110	FP 50	50 H7	95	130	108.9	108.9	M8

Tab. 25

> Linear units in parallel

Synchronization kit for use of ELM linear units in parallel

When movement consisting of two linear units in parallel is essential, a synchronization kit must be used. This consists of original Rollon lamina type precision joints complete with tapered splines and hollow aluminum drive shafts.

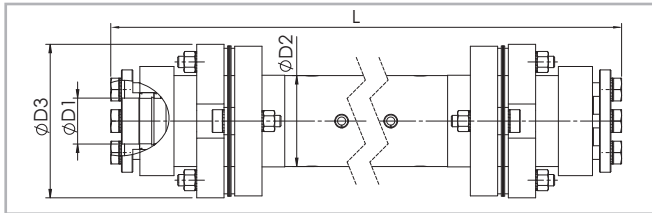

Fig. 12

Moment of inertia [g·mm²] C1 + C2 · (X-Y)

	C1	C2	Y	Weight [Kg] D1+D2 · (X-Y)	
	[g·mm ²]	[g·mm ²]	[mm]	D1 [Kg]	D2 [Kg mm]
GK12P	61.456	69	166	0.308	0.00056
GK15P	906.928	464	210	2.28	0.00148
GK20P	1.014.968	464	250	2.48	0.00148
GK25P	5.525.250	4.708	356	6.24	0.0051

Tab. 26

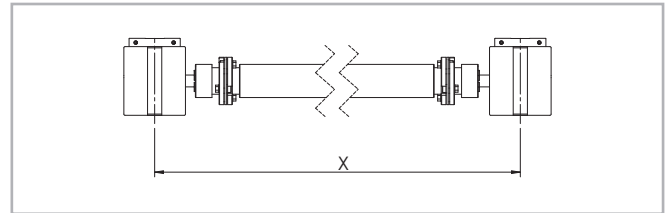

Fig. 13

Dimensions (mm)

Applicable to unit	Shaft type	D1	D2	D3	Code	Formula for length calculation
ELM 50	AP 12	12	25	45	GK12P...1A	L= X-73mm
ELM 65	AP 15	15	40	69.5	GK15P...1A	L= X-90mm
ELM 80	AP 20	20	40	69.5	GK20P...1A	L= X-116mm
ELM 110	AP 25	25	70	99	GK25P...1A	L= X-162mm

Tab. 27

> Accessories

Fixing by brackets

The linear motion system used for the ELM series linear units enables them to support loads in any direction. They can therefore be installed in any position.

To install the units, we recommend the use of the dedicated T-slots in the extruded bodies as shown below.

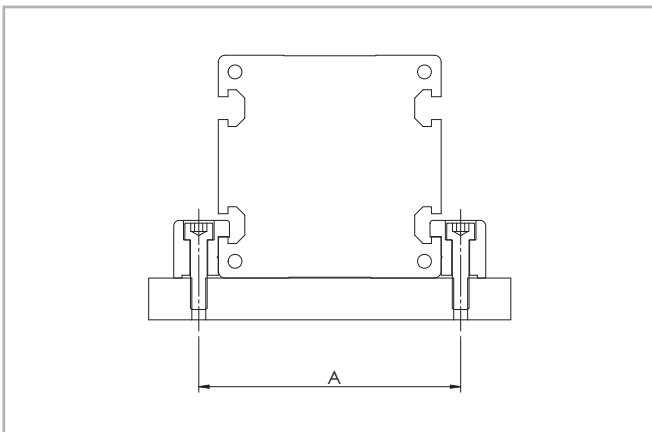

Fig. 14

PLS-12

Unit	A (mm)
ELM 50	62
ELM 65	77
ELM 80	94
ELM 110	130

Tab. 28

Warning:

Do not fix the linear units through the drive ends.

Fixing brackets

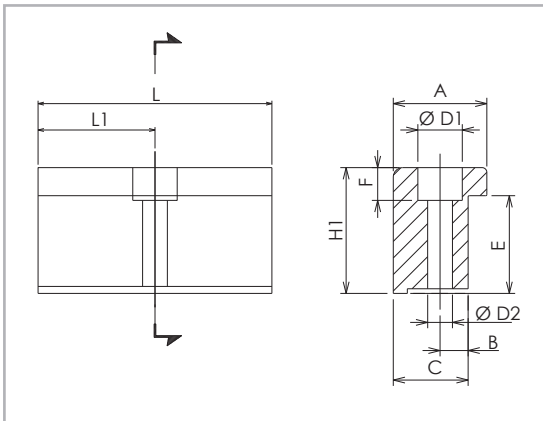

Fig. 15

Dimensions (mm)

Unit	A	H1	B	C	E	F	D1	D2	L	L1	Code
ELM 50	20	14	6	16	10	6	10	5.5	35	17.5	1000958
ELM 65	20	17.5	6	16	11.5	6	9.4	5.3	50	25	1001490
ELM 80	20	20.7	7	16	14.7	7	11	6.4	50	25	1001491
ELM 110	36.5	28.5	10	31	18.5	11.5	16.5	10.5	100	50	1001233

Tab. 29

Fixing bracket

Anodized aluminum block for fixing the linear units through the side T-slots of the body.

T-Nuts

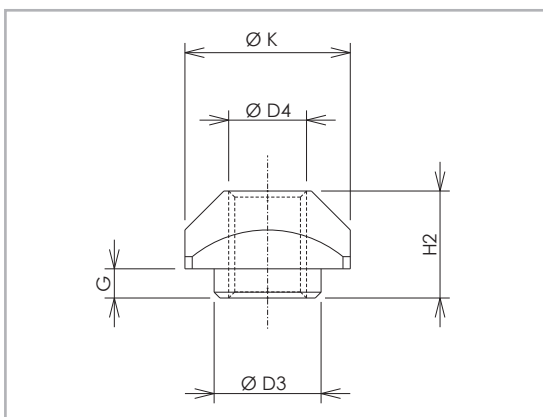

Fig. 16

Dimensions (mm)

Unit	D3	D4	G	H2	K	Code
ELM 50	-	M4	-	3.4	8	1001046
ELM 65	6.7	M5	2.3	6.5	10	1000627
ELM 80	8	M6	3.3	8.3	13	1000043
ELM 110	11	M8	2.8	10.8	17	1000932

Tab. 30

T-nuts

Steel nuts to be used in the T-slots of the body.

Proximity ELM

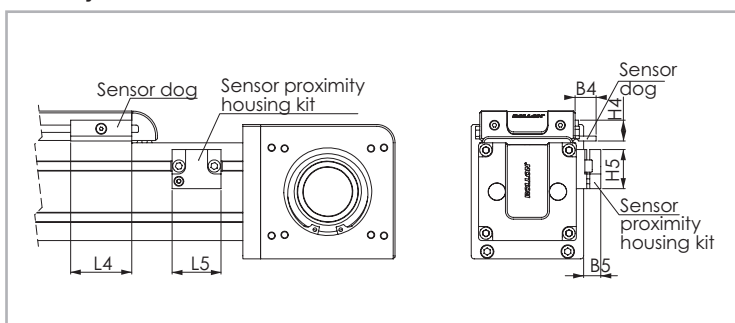

Fig. 17

Sensor proximity housing kit

Red anodized aluminum sensor holder, equipped with T-nuts for fixing onto the profile.

Sensor dog

L-shaped bracket in zinc-plated iron, mounted on the carriage and used for proximity switch operations.

Dimensions (mm)

Unit	B4	B5	L4	L5	H4	H5	For proximity	Sensor dog code	Sensor proximity housing kit code
ELM 50	9.5	14	25	29	11.9	22.5	Ø 8	G000268	G000211
ELM 65	17.2	20	50	40	17	32	Ø 12	G003574	G000212
ELM 80	17.2	20	50	40	17	32	Ø 12	G000267	G000209
ELM 110	17.2	20	50	40	17	32	Ø 12	G000267	G000210

Tab. 31

Gearbox assembly kit

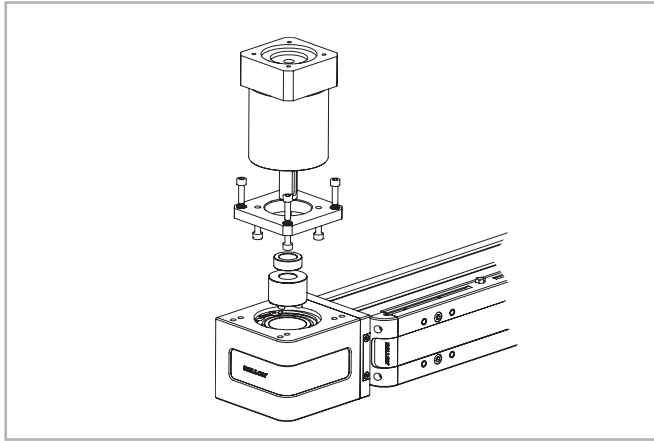

Fig. 18

Codes on the the table below refer to the gearbox assembly kit.
The kit includes: shrink disk; adapter plate; fixing hardware.

Unit type	Gearbox type (not included)	Kit Code
ELM 50	MP060	G000566
	LC050; PE2; NP005S	G001444
ELM 65	MP080	G000529
	MP060; PLE060	G000531
	SW030	G000748
	PE3; NP015S; LC070	G000530
ELM 80	P3	G001162
	P3	G000824
	MP080	G000826
	LC090; MPV01; NP025S; PE4	G000827
	MP105	G000830
	PE3; NP015S; LC070	G001078
	SP075; PLN090	G000859
	SP060; PLN070	G000829
	SW040	G000866
	ELM 110	MP130
LC120; MPV02; NP035S; PE5; AE120		G000483
LC090; NP025S; PE4; NP025S		G000525
MP105		G000527
SW050		G000717
SP075; PLN090; P4; VRS075; AF075A		G000526

Tab. 32

For other gearbox type ask Rollon

Single shrink disc

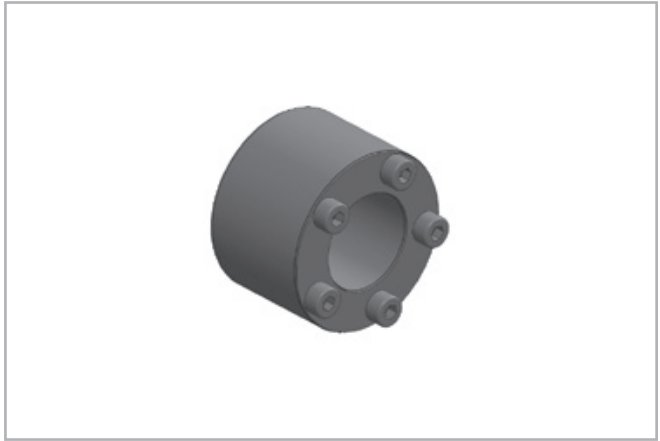

Fig. 19

Codes on the table below refer to a shrink disc ordered as single element.

Unit type	Hollow shaft [mm]	Shrink disc dxD [mm]	Transmittable torque* [Nm]	Shrink disc code
ELM 50	26	14x26	36	6005740
		14x34	64	6005737
ELM 65	34	16x34	73	6005738
		19x34	87	6005739
		19x41	150	6005734
ELM 80	41	22x41	174	6005735
		25x41	198	6005736
		22x50	286	6005730
ELM 110	50	25x50	324	6005731
		32x50	415	6005732

* Transmittable torque in the table represents the maximum capacity of the shrink disk. For the application, the limit of F_x must be considered too. **Tab. 33**

Ordering key

> Identification codes for the ELM linear unit

E	06 05=50 06=65 08=80 11=110	1R	2000	1R	D	
						Multiple carriage
						Linear motion system <i>see pg. PLS-4</i>
						L = total length of the unit
						Driving head code
						Linear unit size <i>see from pg. PLS-5 to pg. PLS-8</i>
						ELM Series <i>see pg. PLS-2</i>

In order to create identification codes for Actuator Line, you can visit: <http://configureactuator.rollon.com>

